

EASTWOOD [8x12]

USER MANUAL

IMPORTANT

Read carefully. Retain for future reference



STILLA

Call us today 1800 784 552
www.stilla.com.au



SAFETY & CARE GUIDELINES

1. Take care when moving and working with the painted panels, use the supplied packaging to avoid damage to painted surfaces.
2. When arranging the shed components for initial check, do not store the panels laid down, stand up where possible.
3. Ensure you fully understand the use of power tools recommended for use in assembling this shed.
4. Eye protection should be worn when necessary, when operating power tools.
5. Suitable Gloves will protect Hands, take care when handling Roof Sheeting and other Metal components
6. Use appropriate sun protection when working outdoors.
7. Secure the shed to a suitable immovable foundation. [We recommend: Concrete Slab or Wooden Heavy Floor]
8. Team lifting of heavy items is recommended to avoid injury.
9. Touch up paint is provided in the installation kit to address minor marks / blemishes to painted surfaces.
10. Do not stand or walk on the roof.
11. Do not lay down panels without protecting the paint

1. **UNPACK & CONFIRM**

Read the safety & care and guidelines. Every part needed to construct your shed is included inside the pack; Frames; panels; doors; windows; hardware kits & roofing. Please fully unpack all the parts & check against the parts checklist before contacting customer service about anything you believe may be missing or damaged. Thank-you!

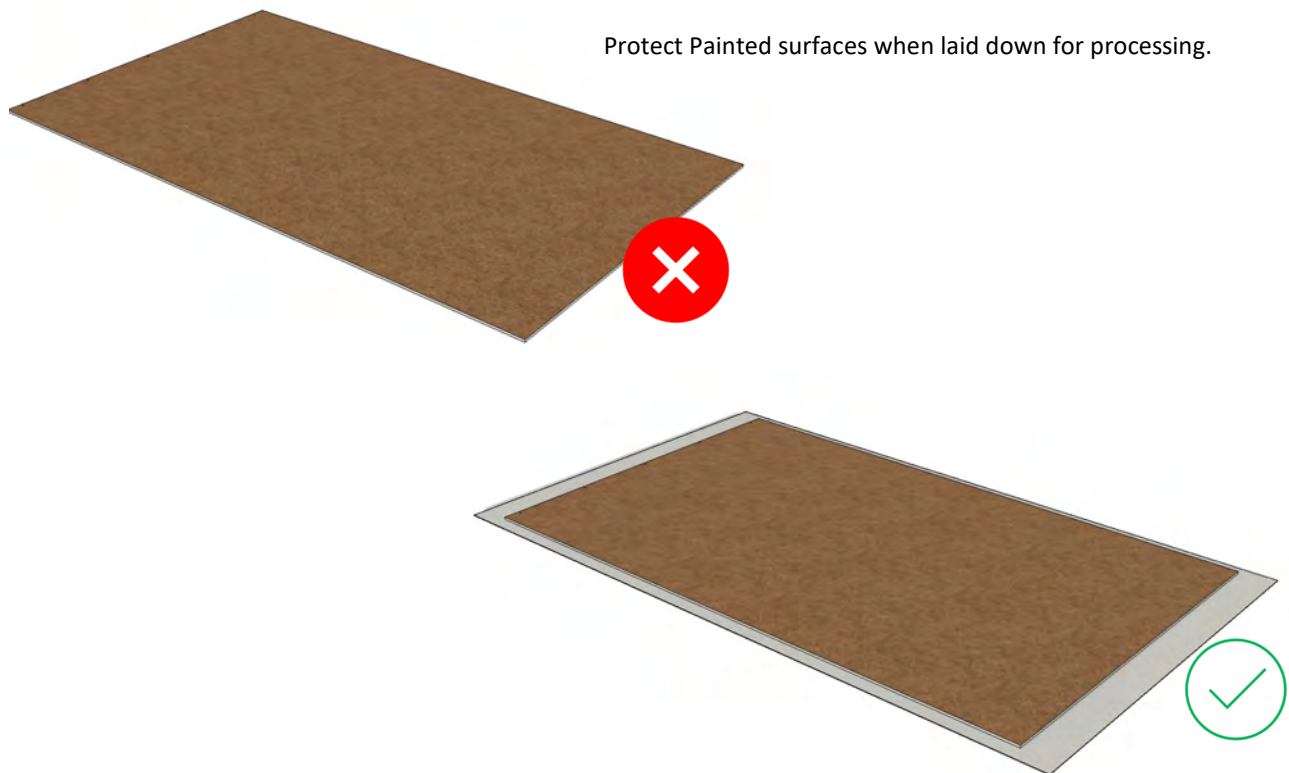

Preparing your site

The installation location needs to be flat, level and solid. Pavers or a solid material that will not be affected by weather can be used to perfectly level the shed by placing under the floor frame where required, make sure all members are supported. If the location is sloped we recommend making level with a slab or Timber floor.

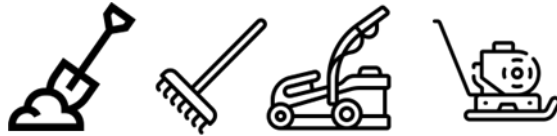

If you are installing your shed on a Stilla floor, this can be placed on unlevelled surfaces and levelled up by using the 100x100 stumps provided. A separate detail is provided for Floor Installation.

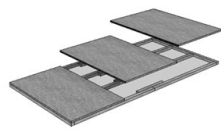

or



For external access during assembly, ensure there is adequate space around the perimeter of the shed assembly space.

Assemble in order presented in this manual. Do not skip any processes.

TOOLS REQUIRED

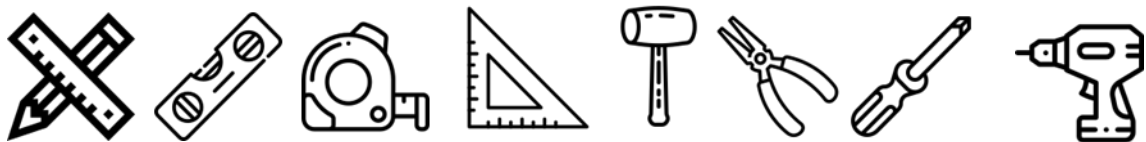

Light coloured crayon/chinagraph pencil white/yellow.

Phillips Bit (PH2), Batten Screw Bit, Phillips Bit #2, 5/16" Hex driver, Drill Bits 3mm & 4mm, Countersink Bit (or Combination.)



This product requires a minimum of 2 persons to assemble.



SHED COMPONENTS

Carefully unpack all the items from shipping carton. Layout in a clean and safe area. Please check you have all components and they have no defects before proceeding.

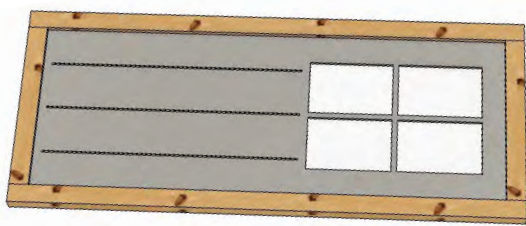





Door Assembly

<p>[2]</p> <p>Door Assy, Door pre assembled</p>	
--	--





WALL — BOTTOM PLATE

<p>[2]</p>  <p>FS295T2, Frame Sill,70mm x 45mm x 295mm Tenon both Ends.</p>	<p>[8]</p>  <p>FS1130T2, Frame Sill,70mm x 45mm x 1130mm Tenon both Ends</p>	<p>[46]</p>  <p>FB20MO/SM Stich Screw #6 x 20mm, Flat Button Head, Panel Fixing to Sill</p>
---	---	---

WALL — UPRIGHTS

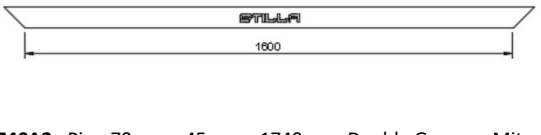
<p>[4]</p>  <p>CP1926 Pine,70mm x 70mm x 1926mm, Corner Post, Plain Ends</p>	<p>[1]</p>  <p>DG1130 Pine,70mm x 45mm x 1130mm, Double Groove, Plain End</p>
<p>[1]</p>  <p>DG1217A1 Pine, 70mm x 45mm x 1217mm, Double Groove, Apex Angle top.</p>	<p>[2]</p>  <p>SG1926A1 Pine 70 x 45 x 1926mm, Single Groove. Miter Top</p>
<p>[4]</p>  <p>DG1926 Pine 70x45x1926mm, Double Groove Plain ends</p>	<p>[240]</p>  <p>PS32CSK, Phillips Screw #6 x 32mm, Countersunk. Panel Fixing to Frame</p>



WALL —TOP PLATE

<p>[1]</p>  <p>DG1740A2, Pine,70mm x 45mm x 1740mm, Double Groove, Mite.</p>	<p>[2]</p>  <p>DG1130T2, Pine,70mm x 45mm x 1130mm, Double Groove, Tenon Ends.</p>
<p>[6]</p>  <p>SG1130T2, Pine,70mm x 45mm x 1130mm, Single Groove, Tenon Ends.</p>	<p>[2]</p>  <p>DG295T2, Pine,70mm x 45mm x 295mm, Double Groove, Tenon Ends.</p>

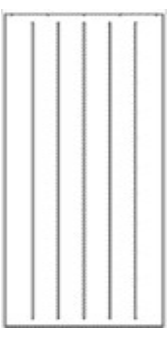
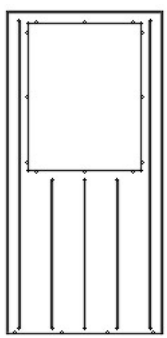
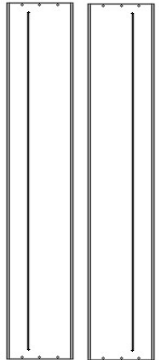



WALL - PANELS

<p>[7]</p>  <p>P1130, Weathertex Panel 1130 x 1824 x 9.5mm, Grooved</p>	<p>[1]</p>  <p>WP1130, Window Panel 1130 x 1824 x 9.5mm, Grooved</p>	<p>[2]</p>  <p>P295, Weathertex Panel 295 x 1824 x 9.5mm, Grooved</p>
--	---	--



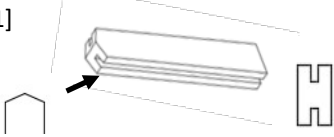



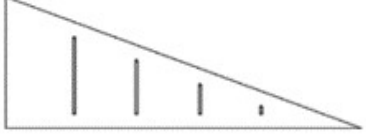







OPENING WINDOW FRAME [1]

<p>[1]</p>  <p>WF-Assy, Painted Window frame [assembled]</p>	<p>[12]</p>  <p>FB20MO/SM Stich Screw #6 x 20mm, Flat Button Head, Fix WF Assy to WP1130 Opening</p>
--	--





ROOF—Gable Frame

<p>[1]</p>  <p>DG421A Pine 70 x 45 x 421mm, Apex angle cut</p>	<p>[4]</p>  <p>SG1299A, Pine, 70 x 45 x 1299mm, Single Groove Angled cut (x4)</p>	<p>[44]</p>  <p>PS32CSK, Phillips Screw #6 x 32mm, Countersunk. Panel Fixing to Door Frame</p>	
<p>[2]</p>  <p>GPL, Gable Panel Left, 1095 x 454 x 9.5mm, 22.5 Degree Pitch</p>		<p>[2]</p>  <p>GPR, Gable Panel Right, 1095 x 454 x 9.5mm, 22.5 Degree Pitch</p>	







ROOF FRAME

<p>[8]</p>  <p>REP1734, Roof End Plate, Pine 70 x 45 x 1734mm.</p>	<p>[8]</p>  <p>RF1135, Roof Frame, Pine 70 x 45 x 1135mm.</p>		
<p>[4]</p>  <p>LP1096, Lock Plate 70x45x1096mm</p>	<p>[2]</p>  <p>CT-A, Collar Tie 720mm</p>		
<p>[12]</p>  <p>RS1400 MO/SM, 6 Rib Roof Sheet 1400mm.</p>	<p>[3]</p>  <p>RC1520 MO/SM, Ridge Cap (A) 1520mm .</p>	<p>[80]</p>  <p>BS75, Batten Screw 75mm Galvanized.</p>	<p>[2]</p>  <p>SB250, Roof Support Block</p>
<p>[6]</p>  <p>CH1520 MO/SM, Channel 1520mm.</p>	<p>[116]</p>  <p>RS50MO/SM, Roofing Screw, #8 x 50mm Neoprene Sealing.</p>	<p>[22]</p>  <p>RD-AS2MO/SM, Rivet AS2.</p>	
<p>[2]</p>  <p>PS75CSK, Phillips Screw #10 x 75mm, Countersunk. SB250 top Fixing</p>	<p>[2]</p>  <p>PS50CSK, Phillips Screw #8 x 50mm, Countersunk. SB250 Bottom Fixing</p>	<p>[12]</p>  <p>PS32CSK, Phillips Screw #6 x 32mm, Countersunk. CT-A Fixing</p>	<p>[9]</p>  <p>BS125, Batten Screw 125mm Galvanized.</p>

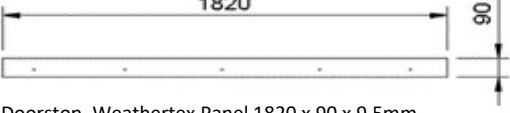

FACIA

<p>[4]</p>  <p>F1500, Painted Facia, 100 x 19 x 1500mm, 22.5 Degree.</p>	<p>[12]</p>  <p>FB173, Painted Block 70 x 45 x 173mm, Facia Spacing Block</p>	<p>[12]</p>  <p>PS32, Phillips Csk Screw #6 x 32mm Treated Pine, Fix F1500 to FB145 .</p>	<p>[12]</p>  <p>BS100, Bugle Batten Screw 100mm Galvanized, Fix FB140 to Gable.</p>
--	---	--	---

FURNITURE

<p>[1]</p>  <p>THB, "T" Handle Black with fixings, Keys and Locking Quadrant</p>	<p>[4]</p>  <p>TH150B, "T" Hinge 150mm, Black with fixings</p>	<p>[3]</p>  <p>DS1820x90, Doorstop, Weathertex Panel 1820 x 90 x 9.5mm</p>
<p>[2]</p>  <p>BB100SS, Barrel Bolt, SS, 100mm plus Hinge Screws [12]</p>	<p>[30]</p>  <p>FB20MO/SM, Stich Screw #6 x 20mm, Flat Button Head, DS Fixing to Door (x8)</p>	<p>[1]</p>  <p>DST1800, Door Stop Top, Weathertex 1800 x 83mm</p>

MISCELLANEOUS

<p>[1]</p>  <p>TU MO/SM, Paint Touchup Monument / Surf mist 500ml</p>	<p>[1]</p>  <p>Sil-MO/SM, Silicone sealant 300ml – coloured</p>
---	---

Anchor Kit **[**Not issued if Heavy Floor is optioned]**

<p>[11]</p>  <p>BKT6040G, Bracket 60mm x 40mm wide, Electro-Galvanised.</p>	<p>[11]</p>  <p>CS650, Concrete screw 6mm x 50mm.</p>	<p>[22]</p>  <p>RS25, Roofing Screw 25mm</p>
---	---	--

WALL CONSTRUCTION—Frame & Panel

MATERIAL SELECTION - Pre-select top plate and upright components for assembly, timber is a natural material, selecting best the best side of components will help the aesthetics of the finished shed.

1

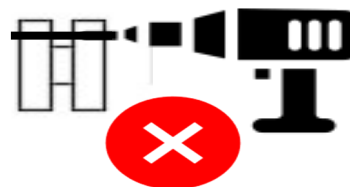
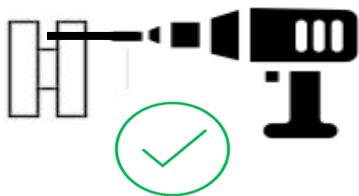

PRE-DRILL - 3mm

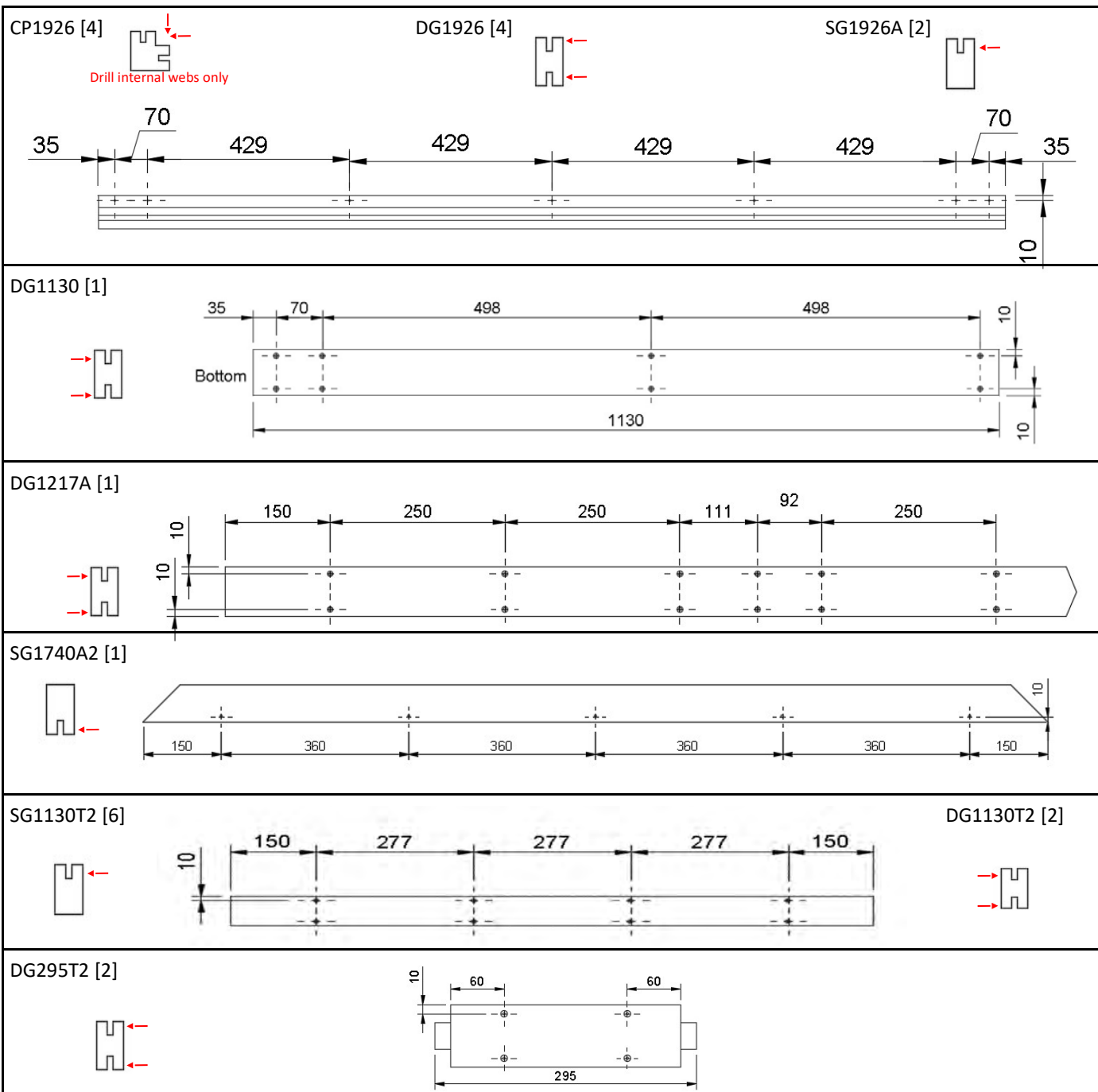

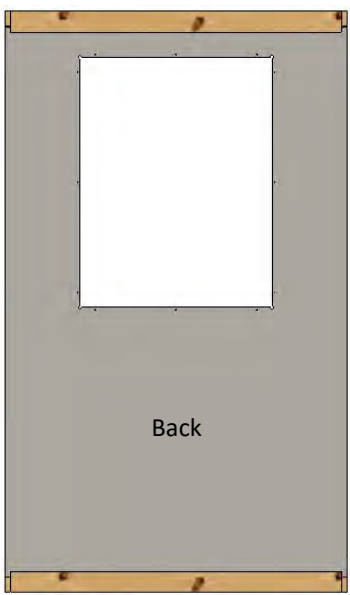
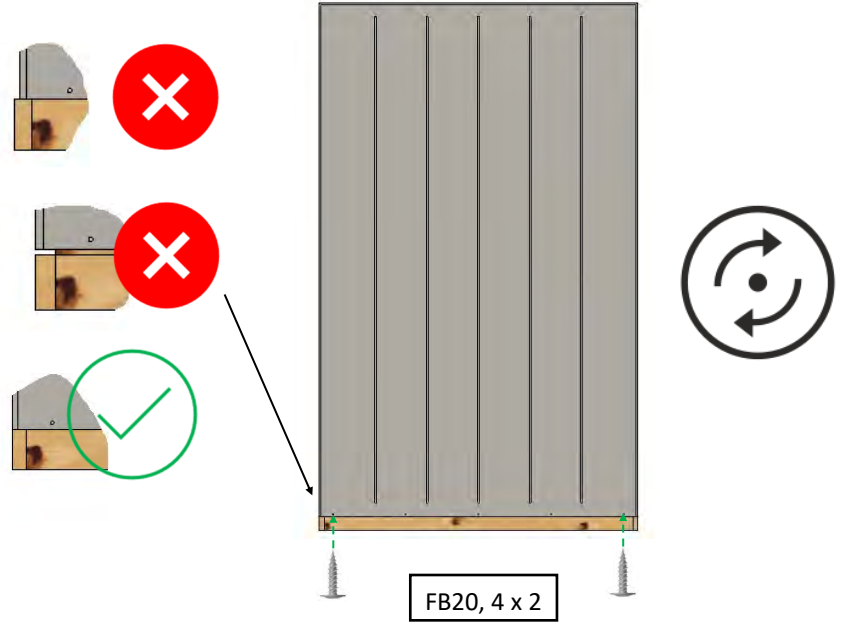
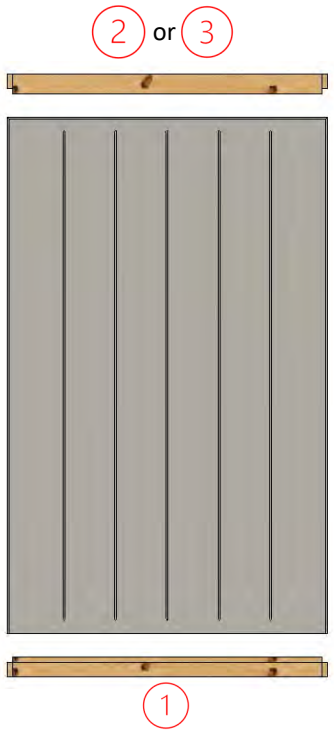

Wall Panel Preparation

<div style="border: 1px solid black; border-radius: 50%; width: 40px; height: 40px; display: flex; align-items: center; justify-content: center; margin: 0 auto;">2</div>	<p>[7]</p>  <p>P1130x1824</p>	<p>[8]</p>  <p>FS1130 1</p>	<p>[1]</p>  <p>WP1130x1824</p>
	<p>[2]</p>  <p>SG1130T2 3</p>	<p>[2]</p>  <p>DG1130T2 2</p>	<p>[16]</p>  <p>PS32CSK</p>
<p>[4x2]</p>  <p>FB20 MO/SM</p>			



NOTE: Window position in shed, will determine Top Plate configuration.

If to be on the Back wall [Opposite doors]. DG1130T2 should be fitted. 



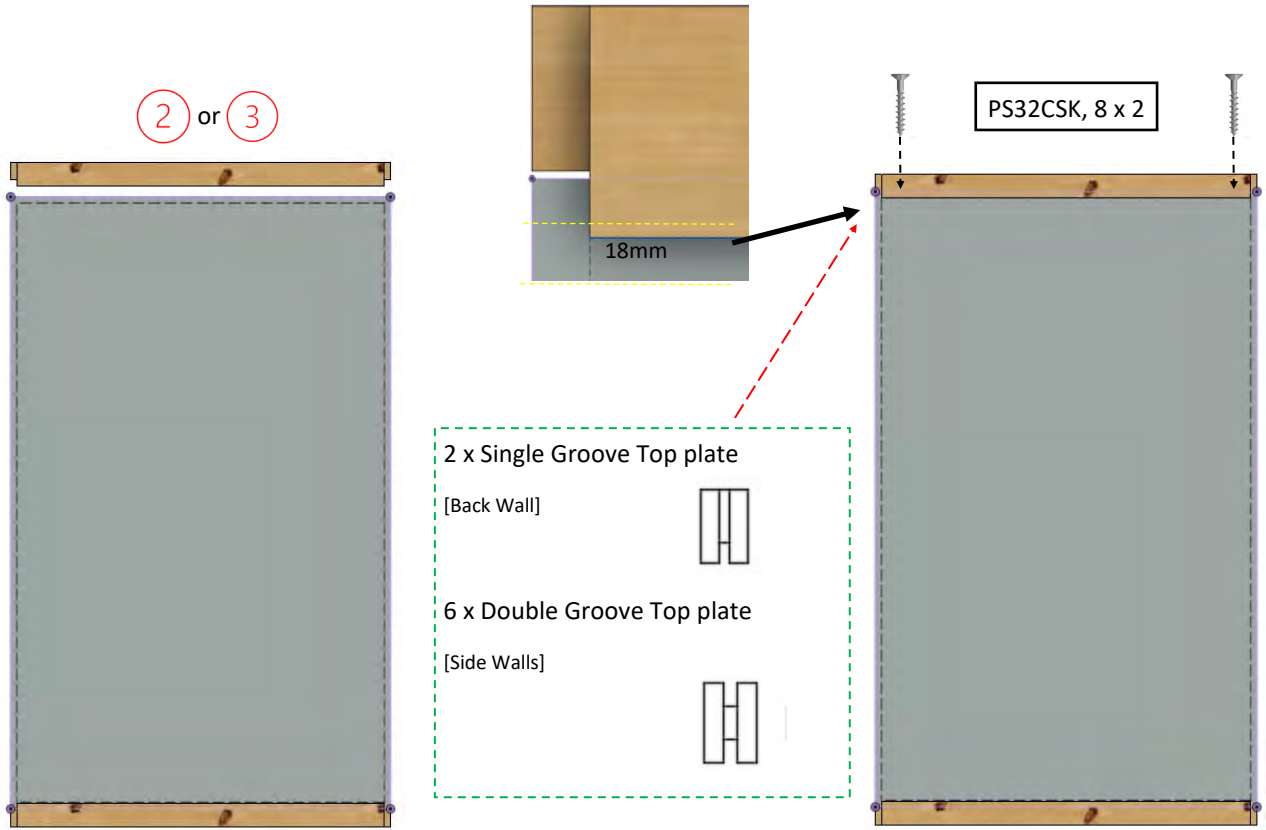

If to be placed in side walls SG1130T2 is required. 

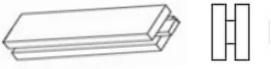

Overall height of panels should be equal to vertical beams [1926mm].

CP1926 or DG1926 can be used as a gauge to ensure ideal panel height of the top plate component.

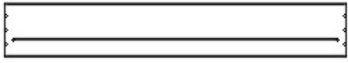

Wall Panel Preparation

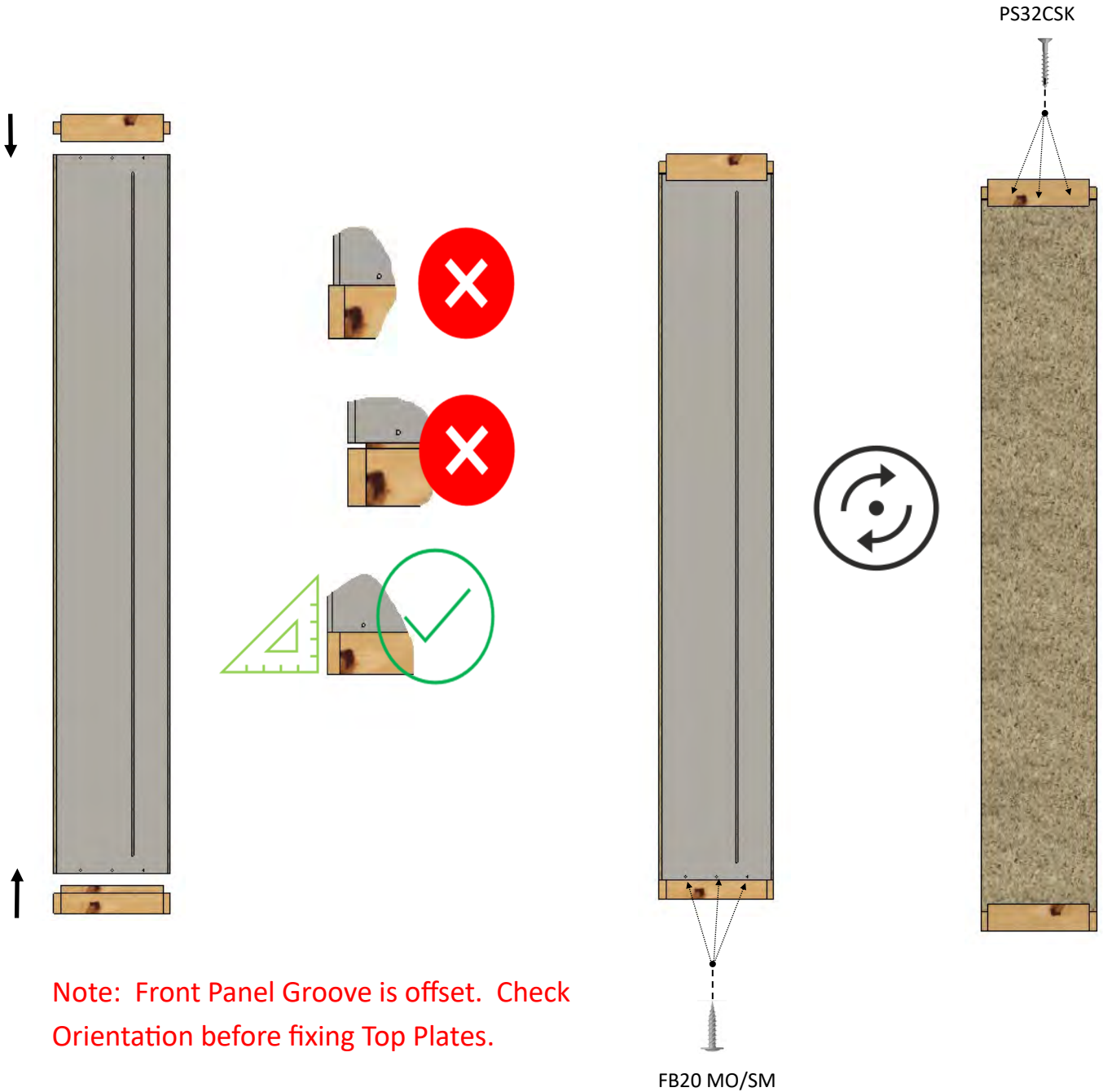
3	[2]	 DG295T2	[2]	 FS295T2	[6]	 FB20 MO/SM
	[2]	 P295x1824			[6]	 PS32CSK



Overall height of panels should be equal to vertical beams [1926mm].

CP1926 or DG1926 can be used as a gauge to ensure ideal panel height of the top plate component.

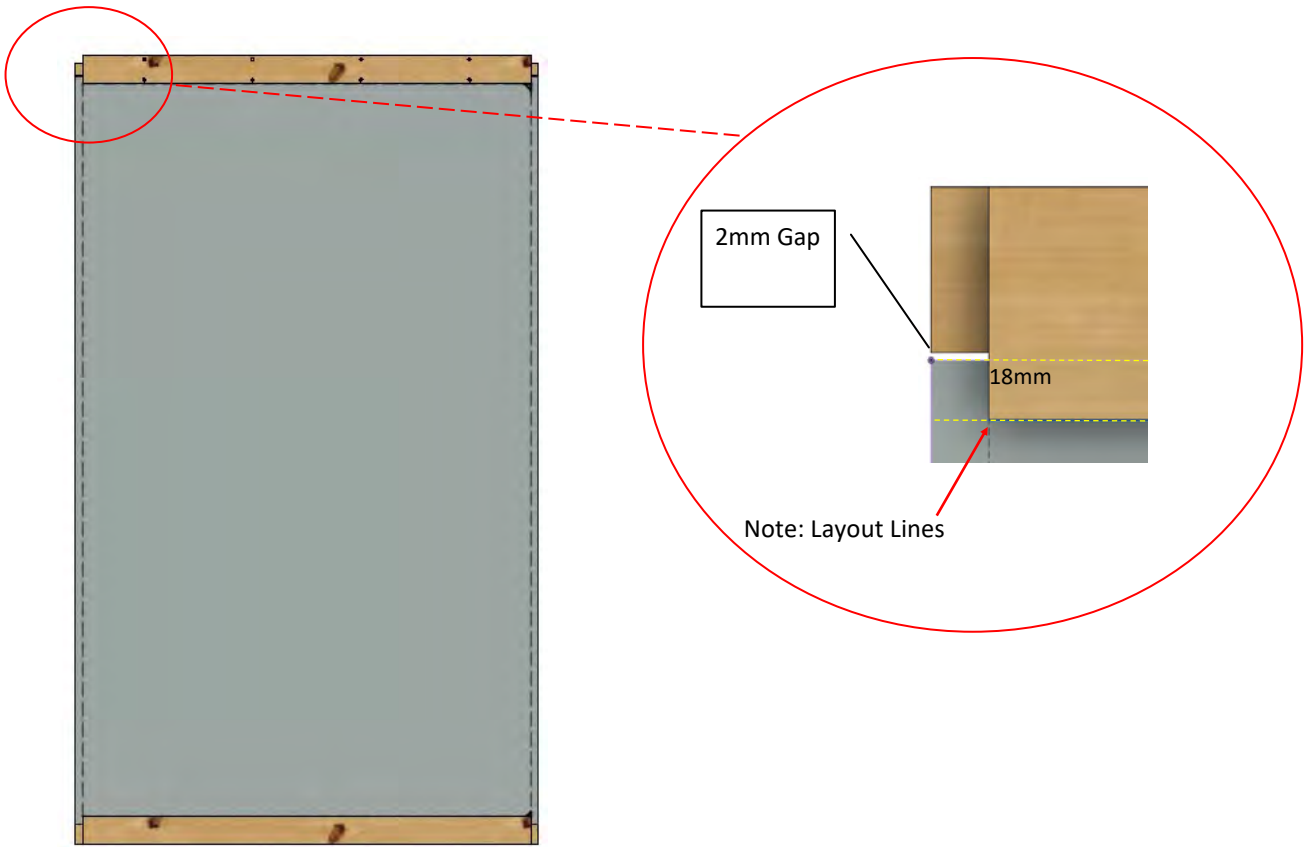

<p style="text-align: center;">4</p>	<p>[1]</p>  <p>Panel Assy Or WP Assy</p>	<p>[1]</p>  <p>CP1924</p>	<p>[2]</p>  <p>PS32CSK</p>
--------------------------------------	---	---	---



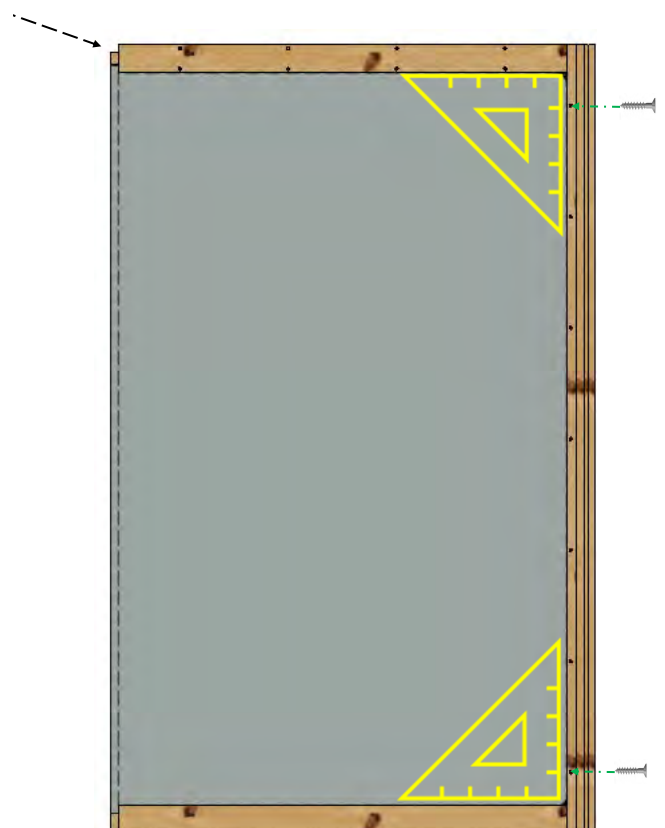
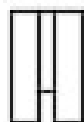

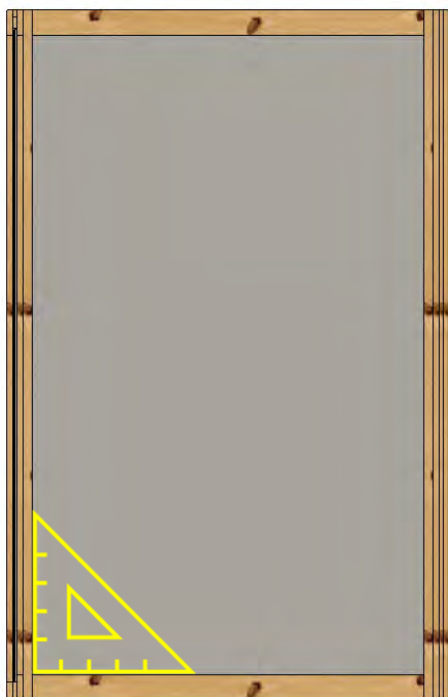
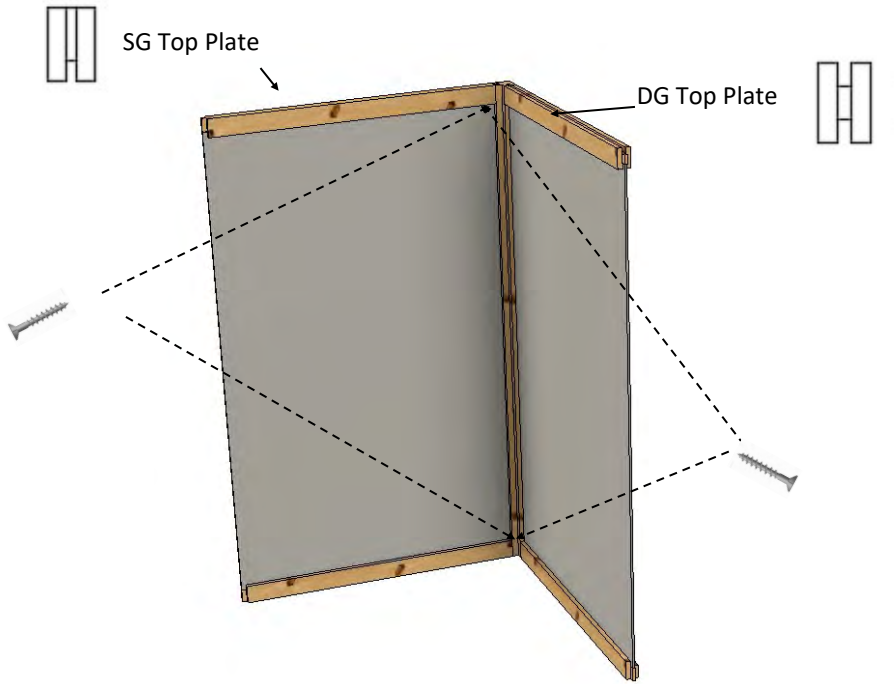
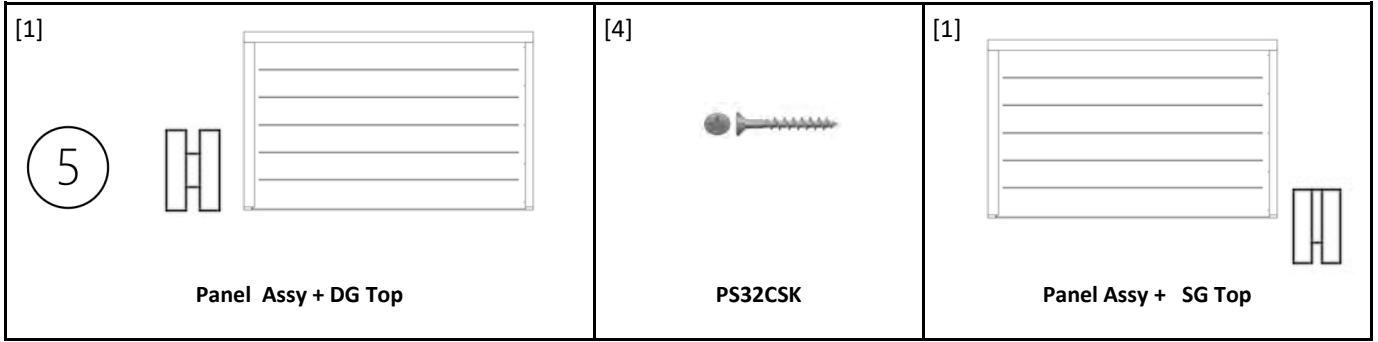

Construct a panel with Corner post on Right Rear face
 [as per image >]
 With SG top Rail [for Side wall]



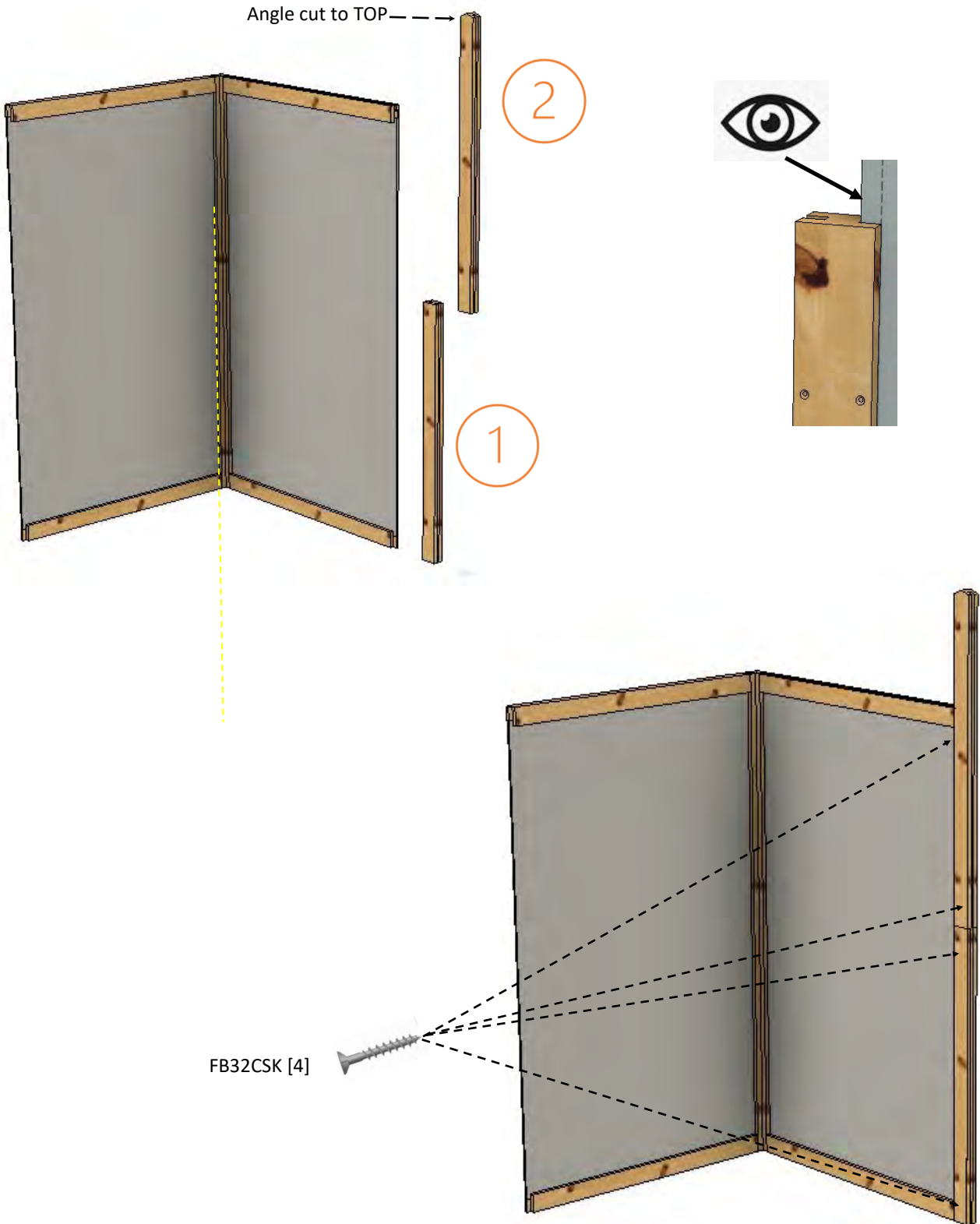





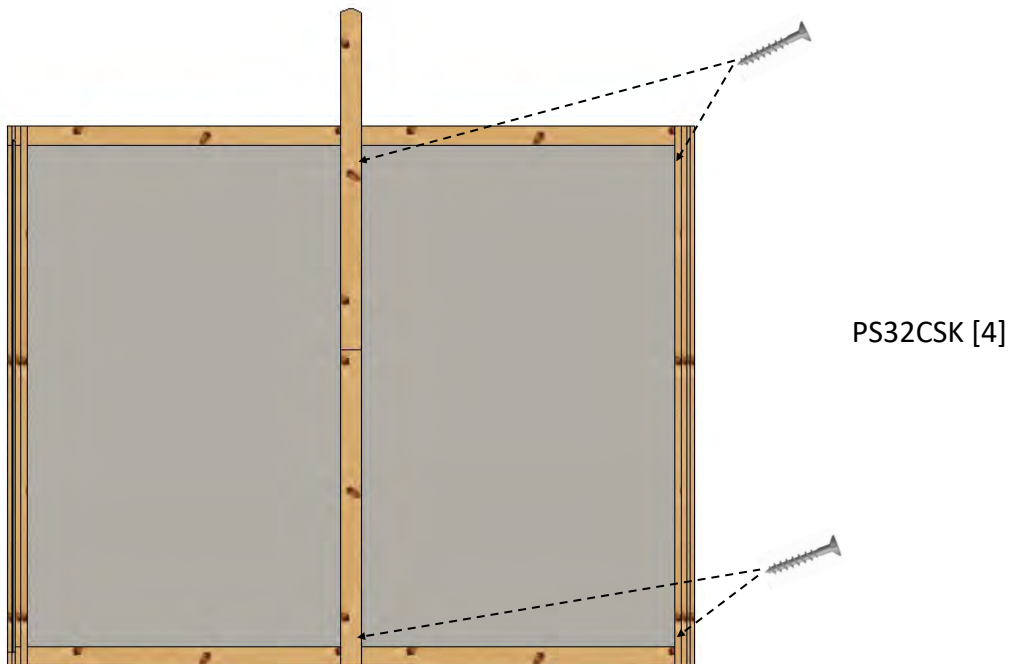

<p style="text-align: center;">6</p>	<p>[1]</p>  <p style="text-align: center;">DG1130</p> <p style="text-align: right;">1</p>	<p>[1]</p>  <p style="text-align: center;">DG1217A1</p> <p style="text-align: right;">2</p>	<p>[4]</p>  <p style="text-align: center;">PS32CSK</p>
--------------------------------------	--	---	---





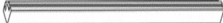

<p>7</p>	<p>[1]</p>  <p>Panel Assy [DG Top]</p> <p>1</p>	<p>[1]</p>  <p>CP1924</p> <p>2</p>	<p>[4]</p>  <p>PS32CSK</p>
----------	--	--	---

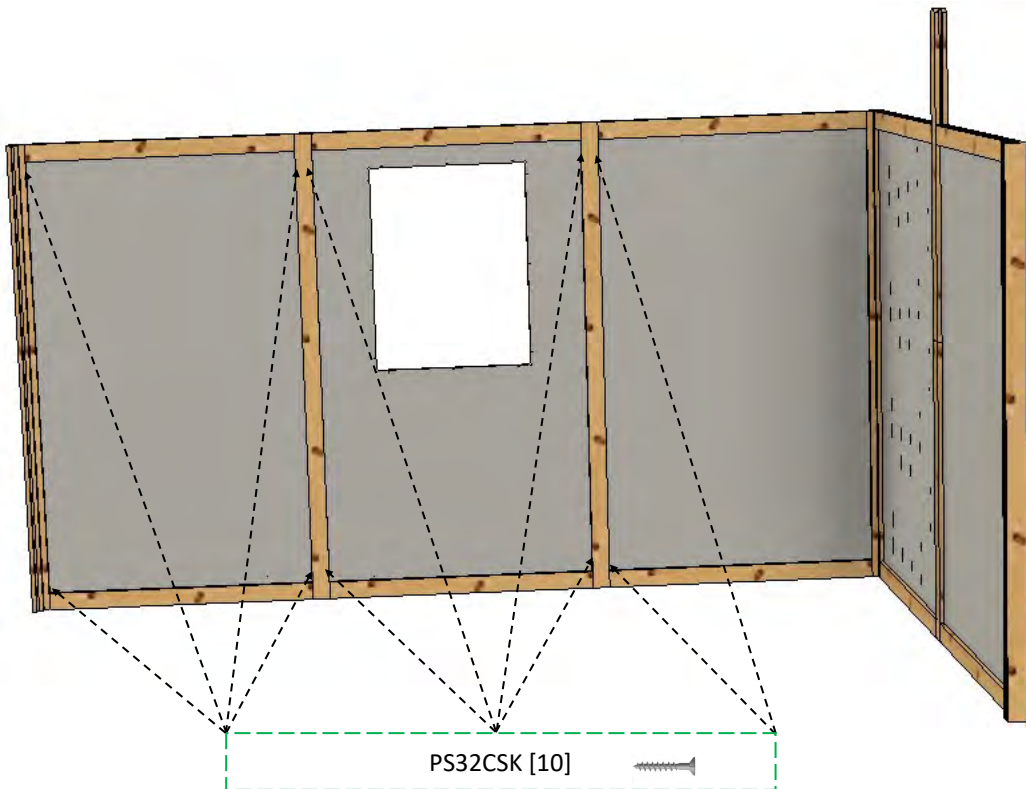
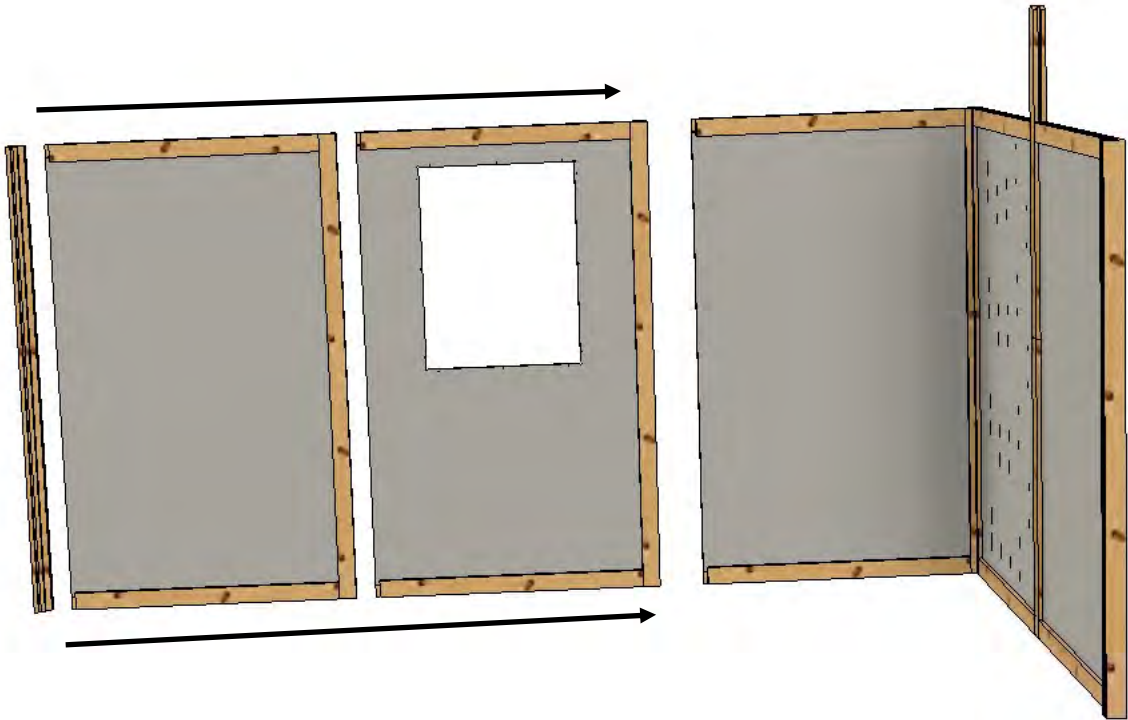

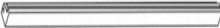

<p style="text-align: center; font-size: 2em;">8</p>	<p>[2]</p>  <p>Panel Assy [SG Top] [Alt 1 WP Assy]</p>	<p>[2]</p>  <p>DG1926 </p>	<p>[1]</p>  <p>CP1924 </p>	<p>[10]</p>  <p>PS32CSK</p>
--	---	--	---	--

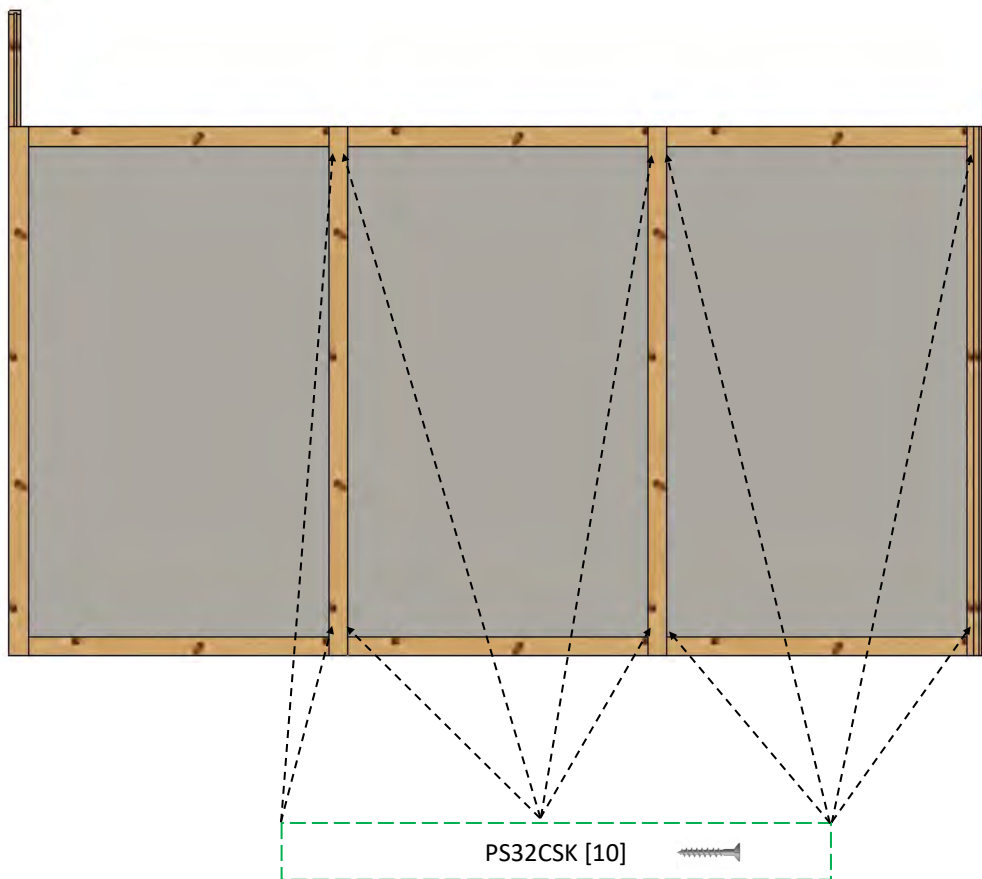
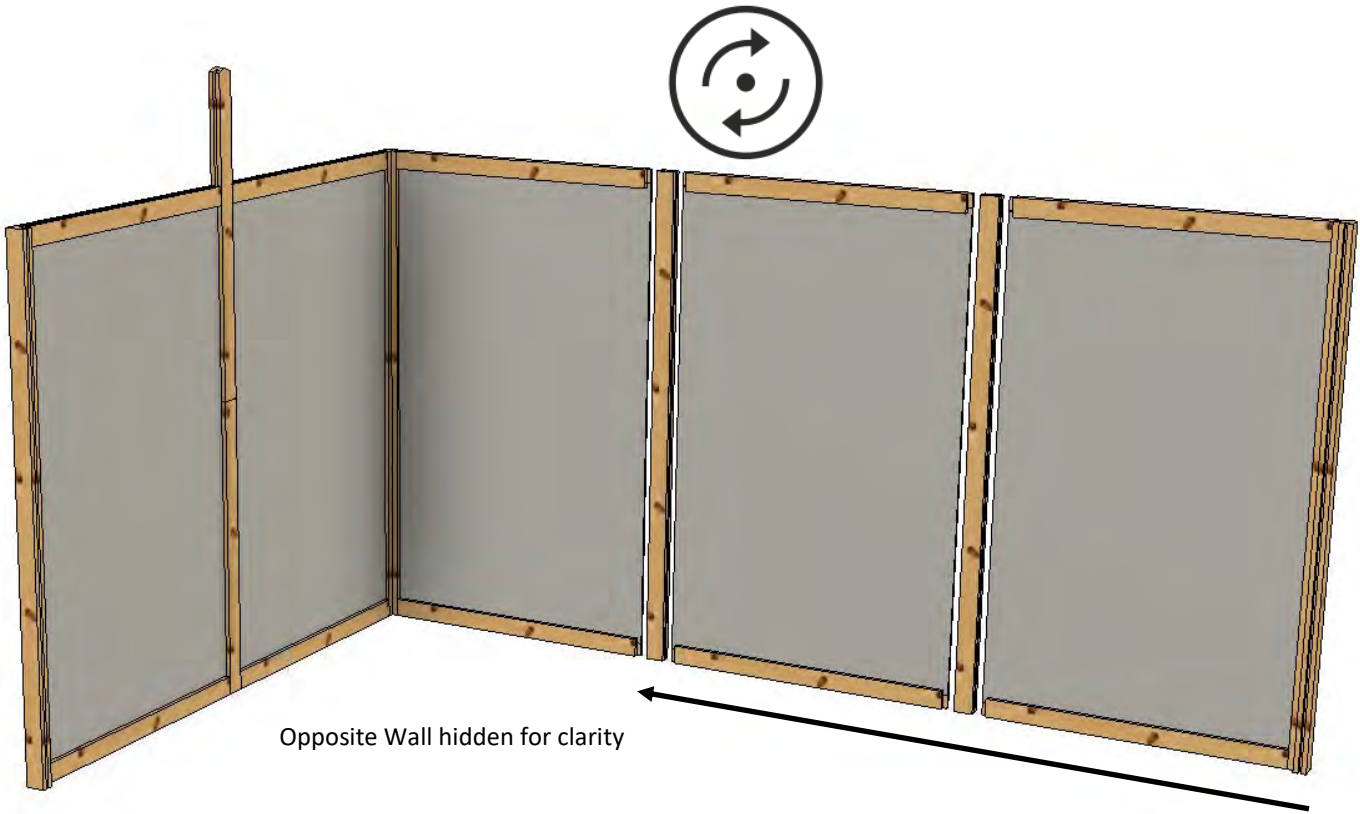

<p>9</p>	<p>[3]  Panel Assy [SG Top] [Alt 1 WP Assy]</p>	<p>[2]  DG1926 </p>	<p>[1]  CP1924 </p>	<p>[10]  PS32CSK</p>
----------	---	--	---	--

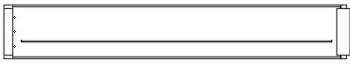

Eastwood [8x12] - 17

<p>10</p>	<p>[2]</p>  <p>Front Panel Assy</p>	<p>[4]</p>  <p>PS32CSK</p>
-----------	--	---

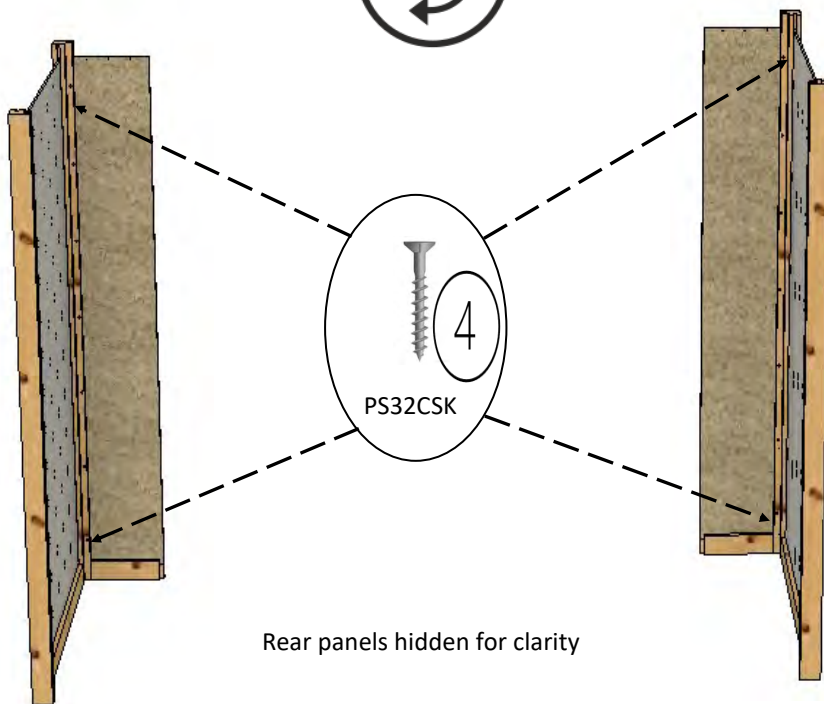
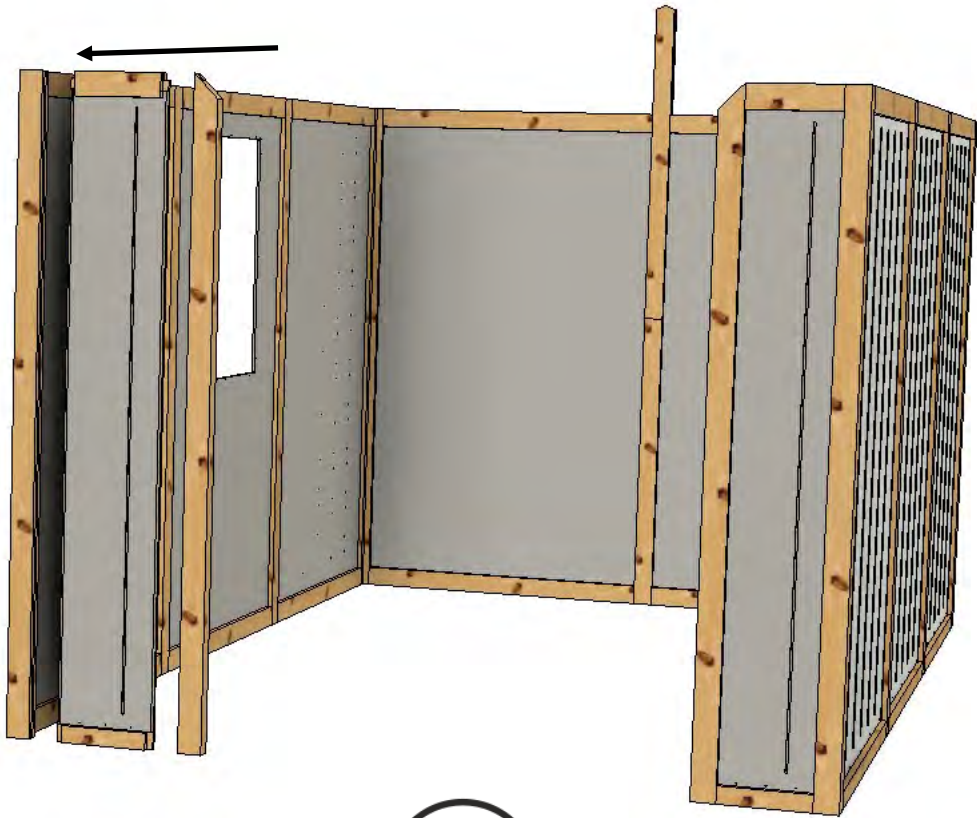

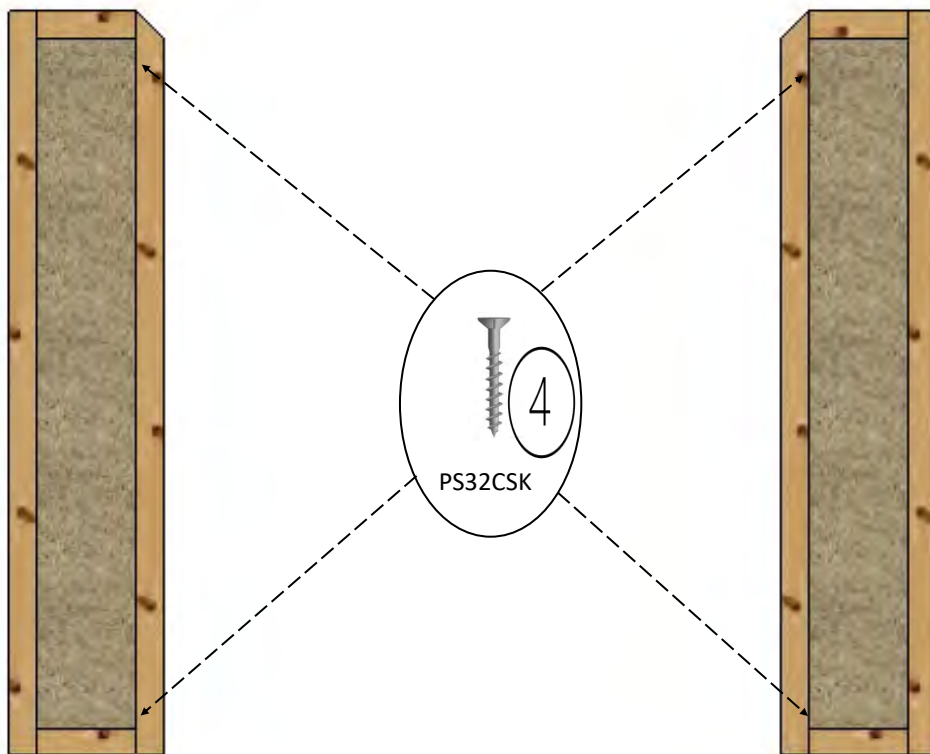
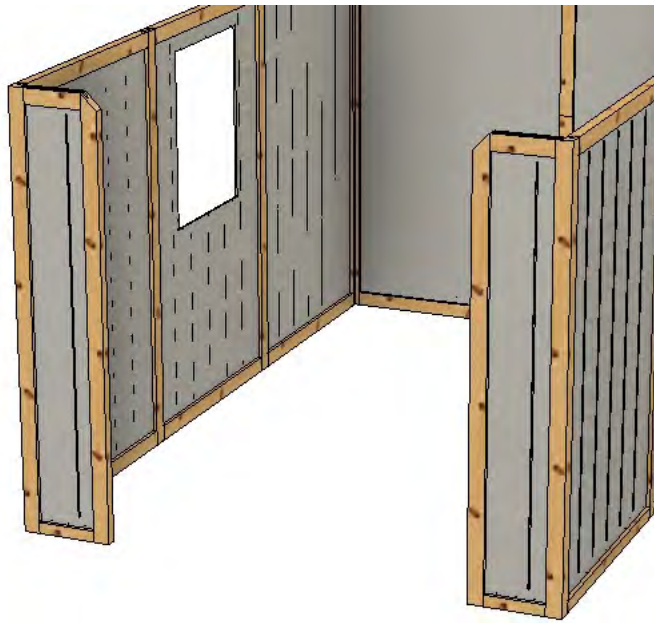

Rear panels hidden for clarity

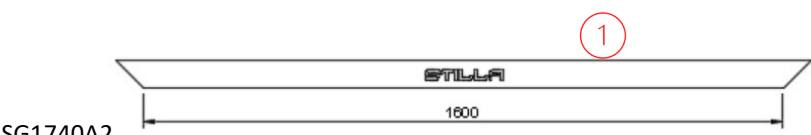

Rear of Door opening shown. Some assemblies hidden for clarity.

Door Head

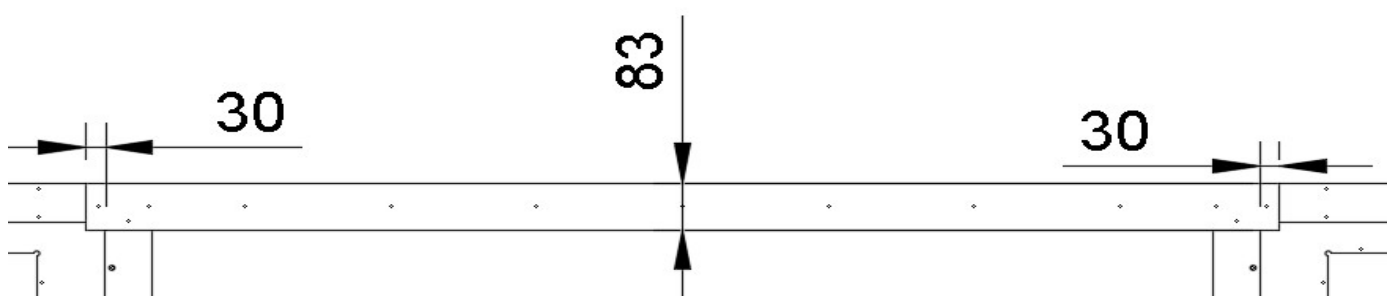
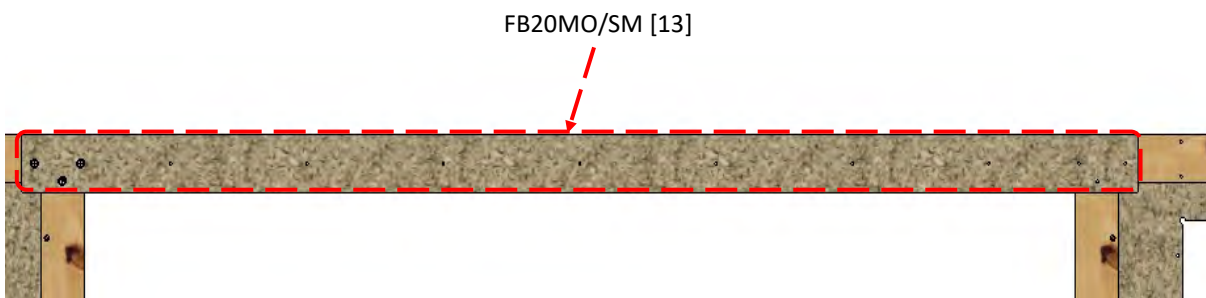
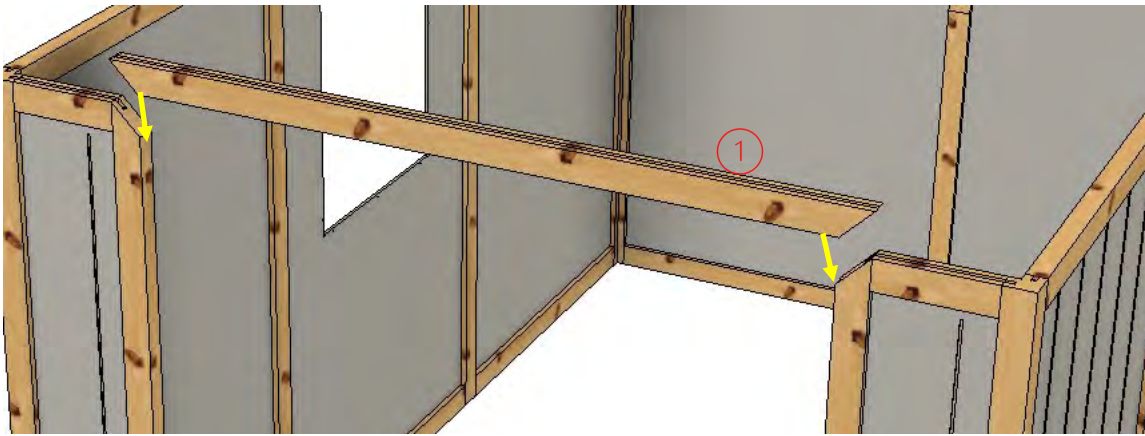

<div style="border: 1px solid black; border-radius: 50%; width: 40px; height: 40px; display: flex; align-items: center; justify-content: center; margin: 0 auto;">11</div>	<p>[1]</p>  <p>SG1740A2</p>	<p>[14]</p>  <p>FB20MO/SM</p>
	<p>[1]</p>  <p>DST1800</p>	

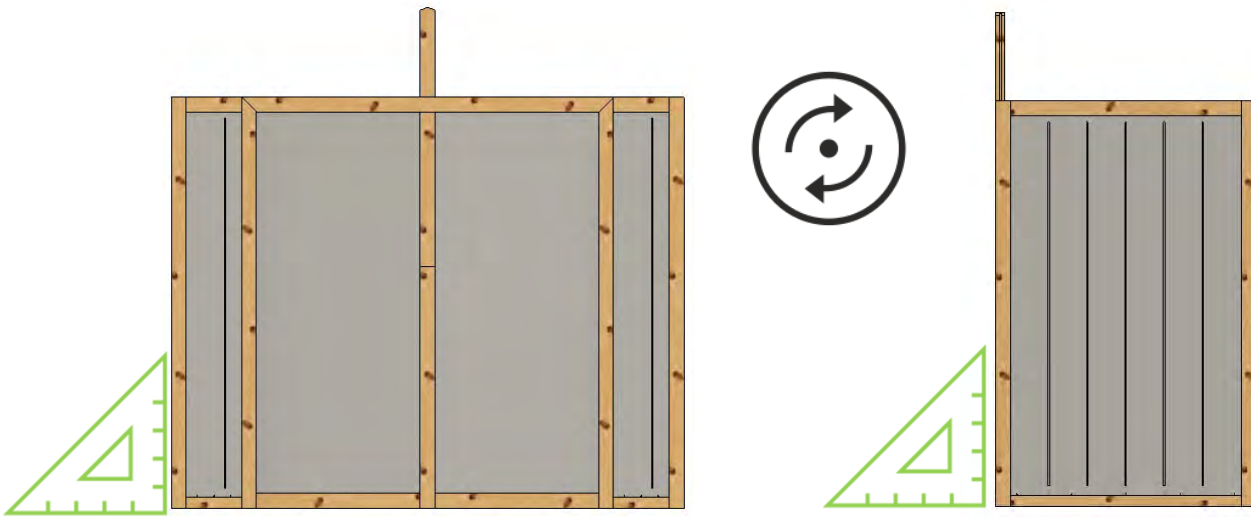



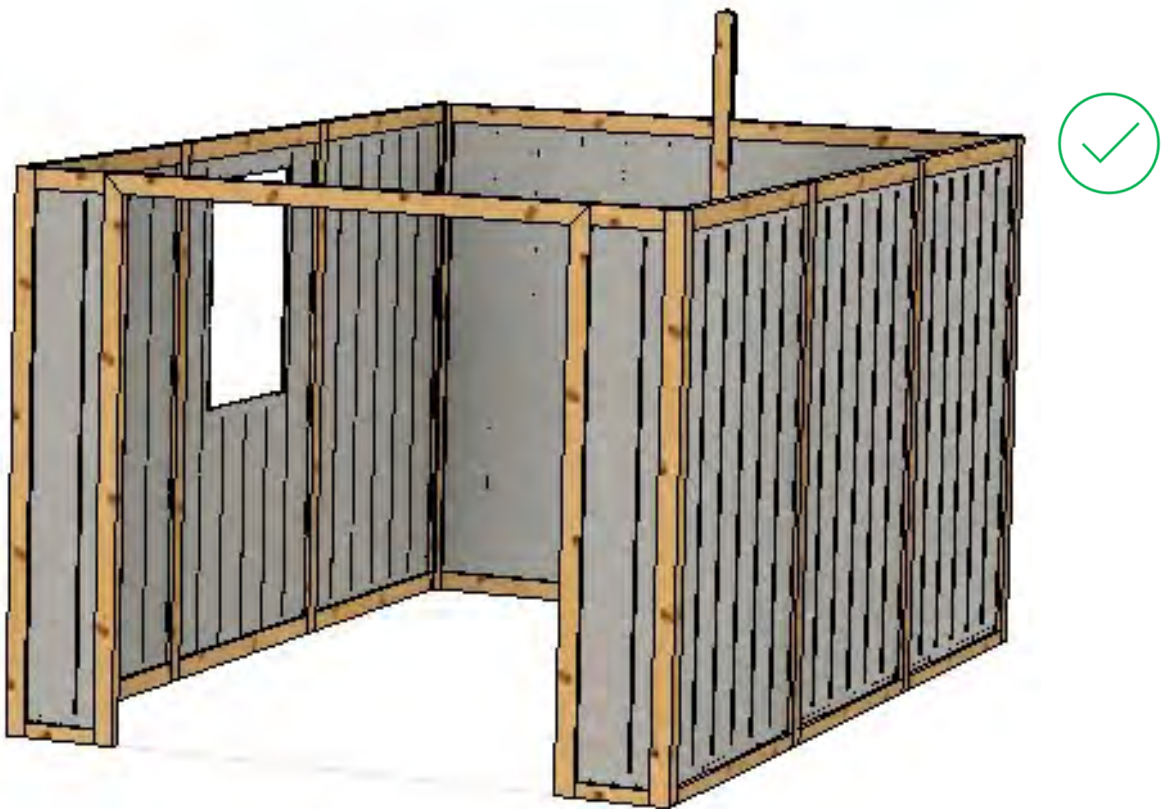



CHECK structure for Square, once confirmed, fit remaining Screws to panels

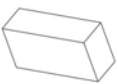

- FB20MO/SM x 26 
- PS32CSK x 177 

GABLES—Preparation

<div style="border: 1px solid black; border-radius: 50%; width: 40px; height: 40px; display: flex; align-items: center; justify-content: center; margin: 0 auto;">12</div>	<p>[4]</p>  <p>SG1299A2</p>	<p>[1]</p>  <p>DG451A1</p>
	<p>[12]</p>  <p>FB173</p>	 <p>BS100</p>

PRE-DRILL - 3mm

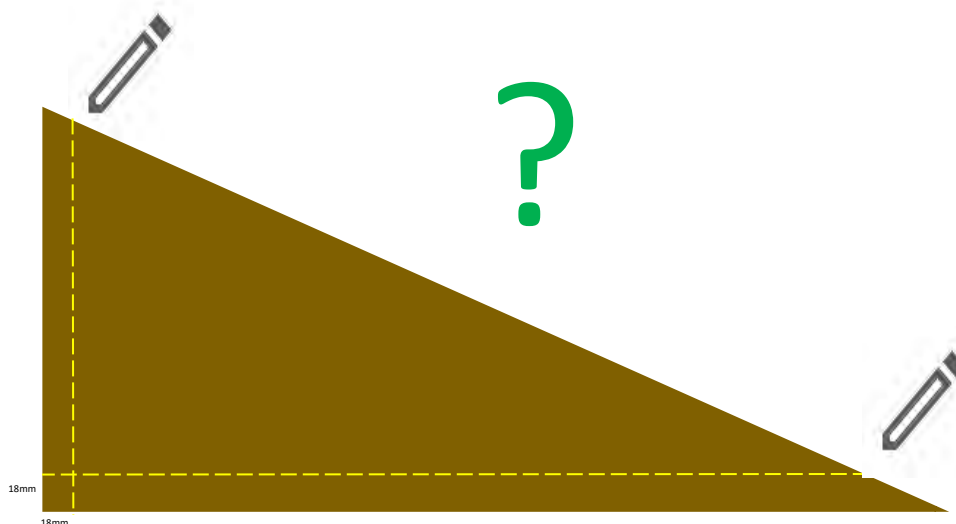
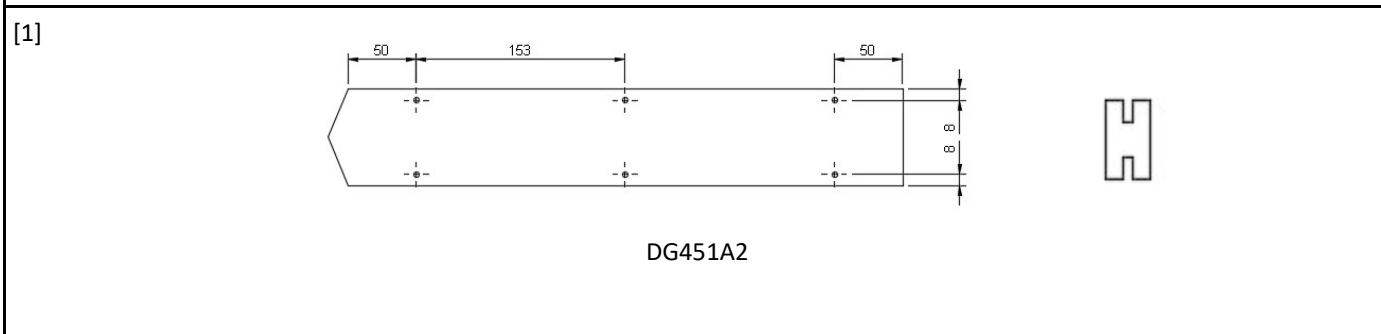
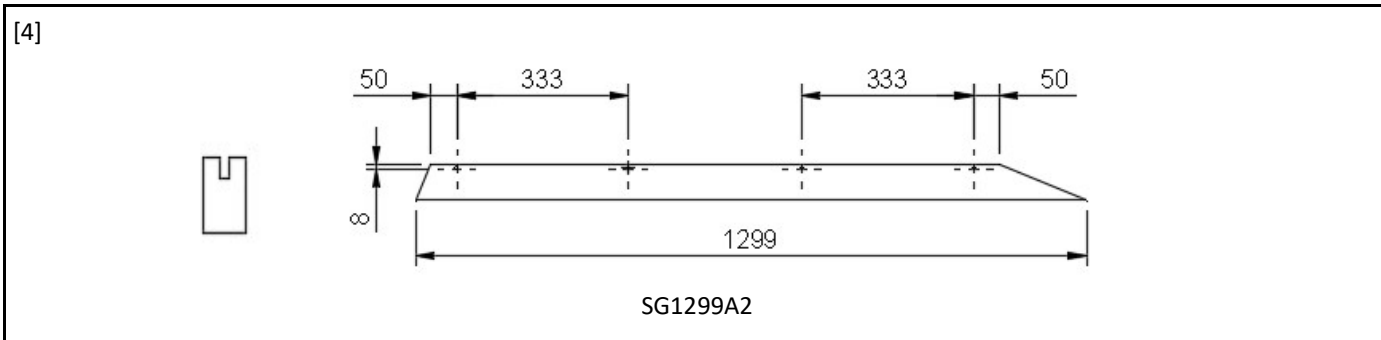
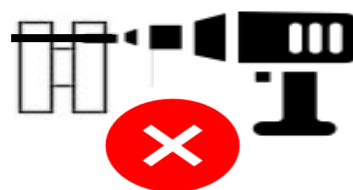
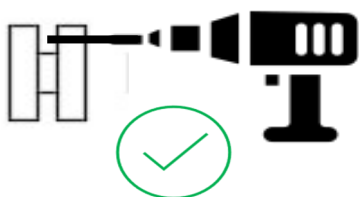

GABLE Angle—Additional Drilling for Facia Block



DRILL 4mm—Through Hole required

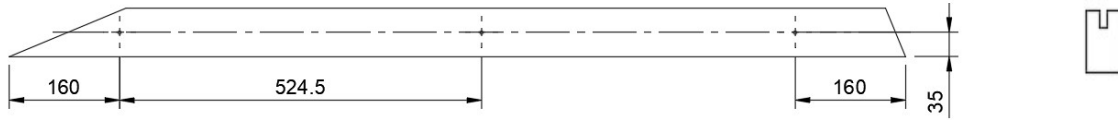

SG1299A2 [4]



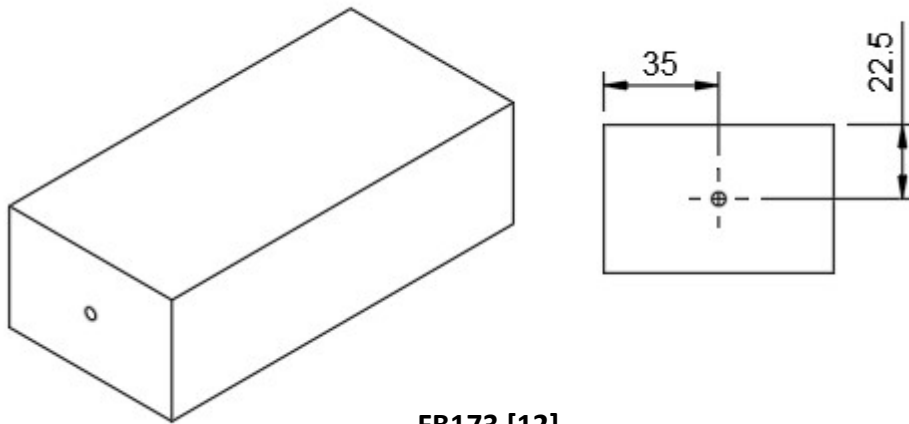

DRILL 4mm—Minimum Depth 50mm

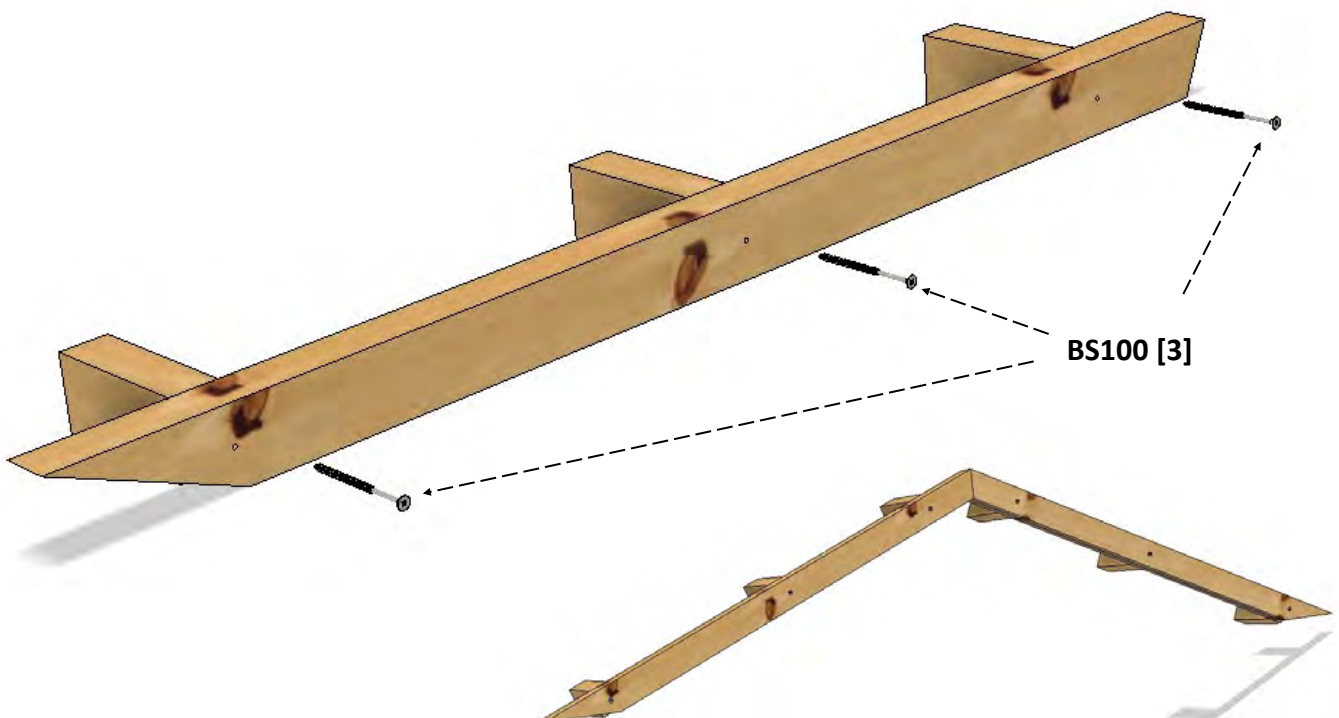

FB173 [12]

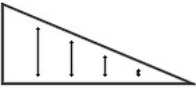

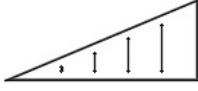
GABLES [2] —Assembly

13a	[2]	 GPR	[4]	 SG1299A2	[48]	
	[2]	 GPL	[1]	 DG421A2		

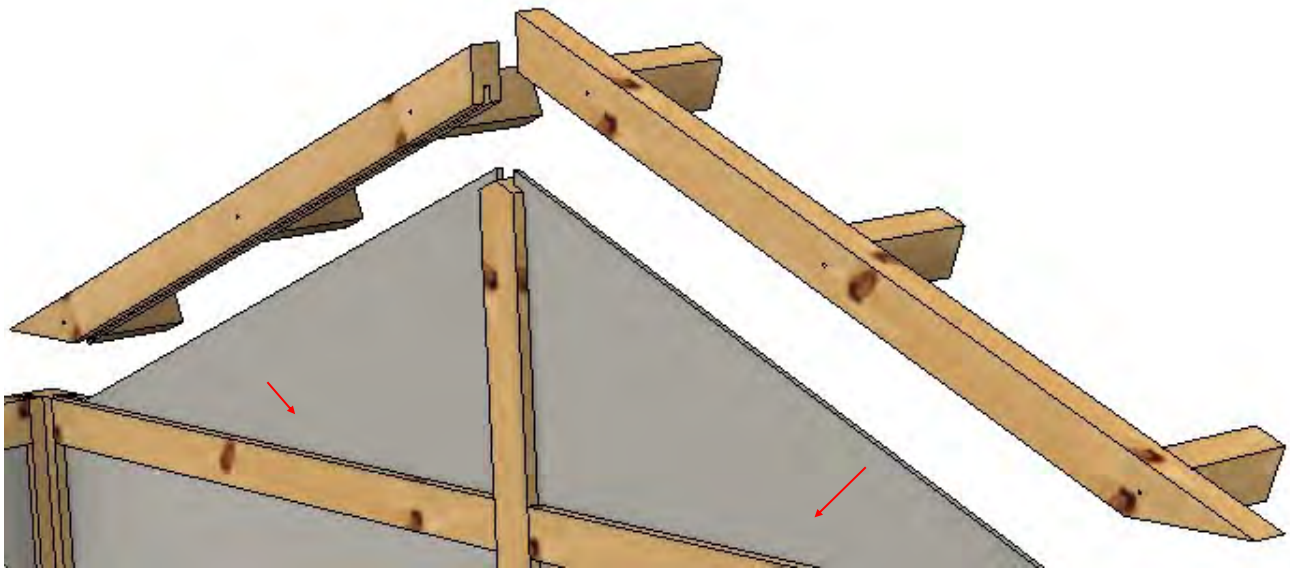
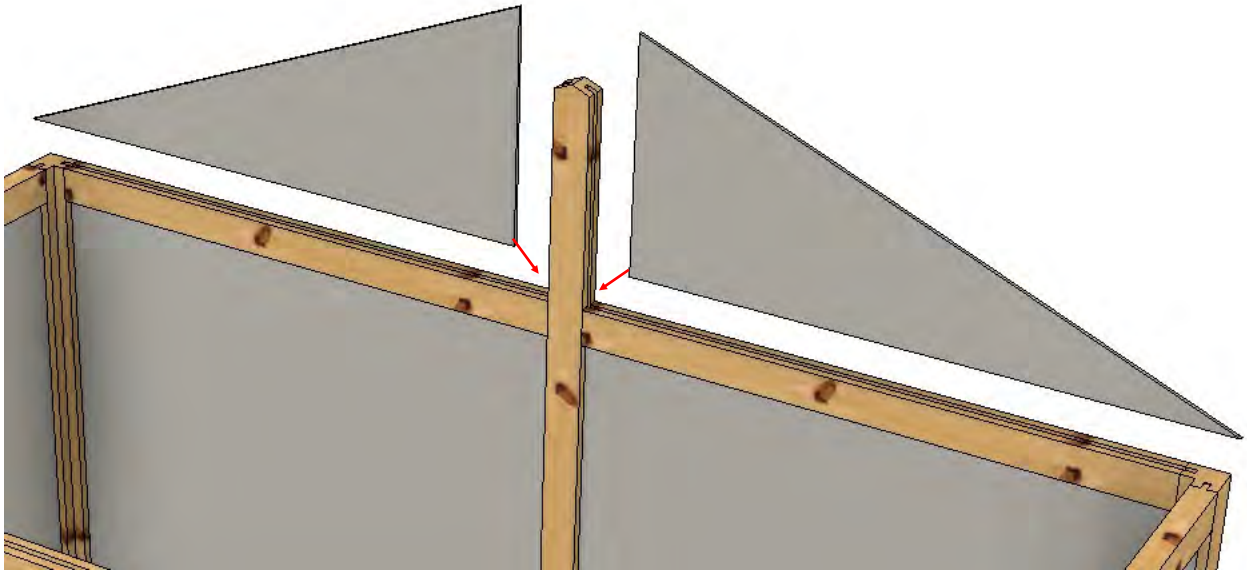



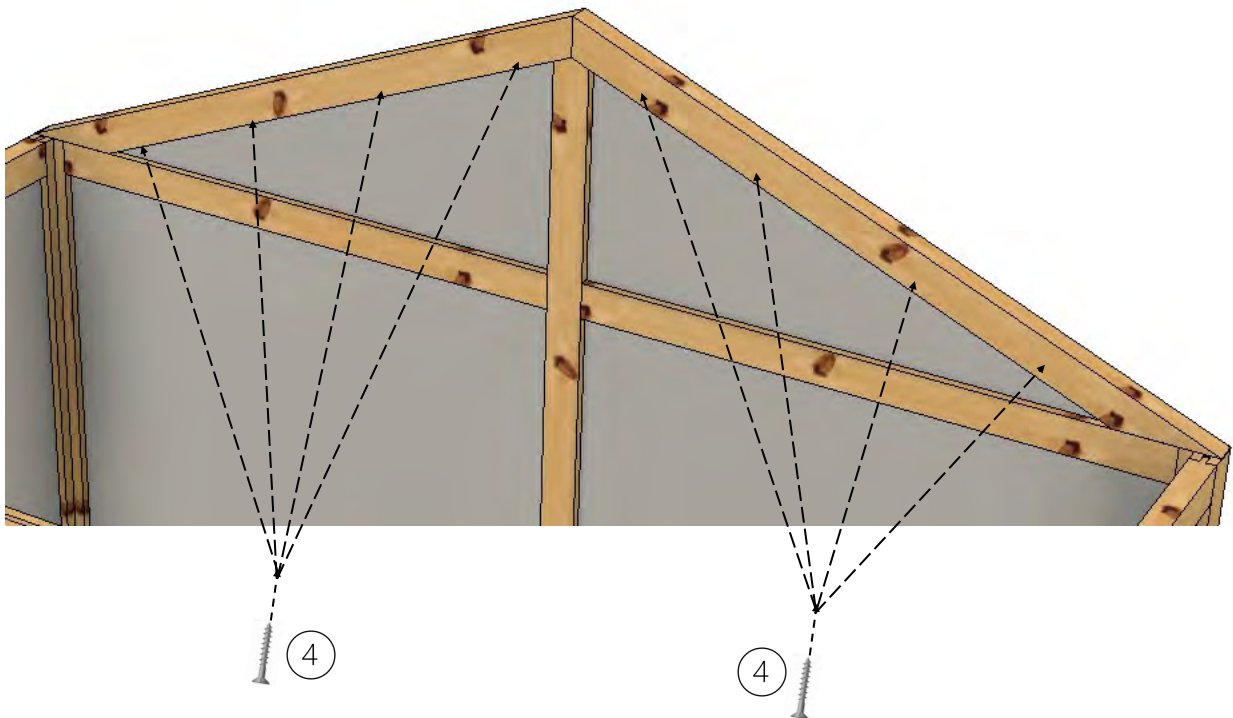
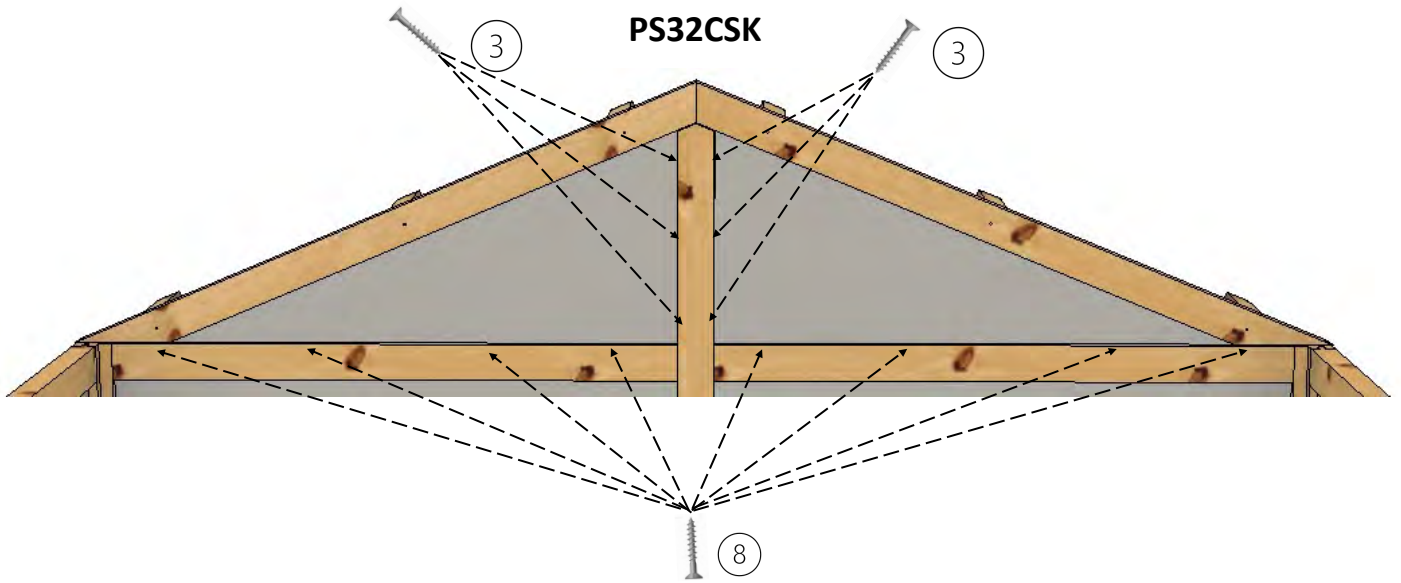

Check Gable position is correct before Fixing in place with screws.

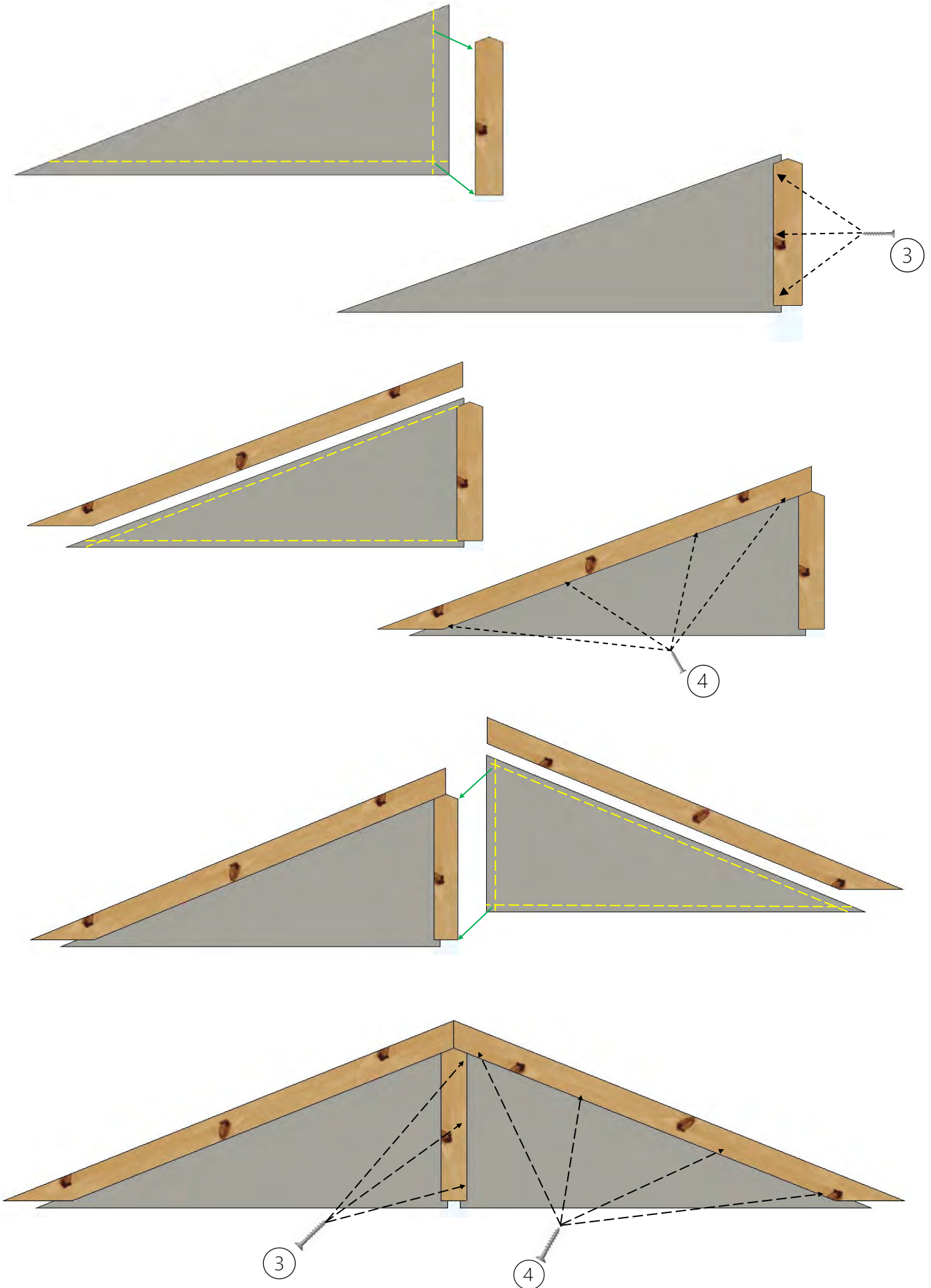

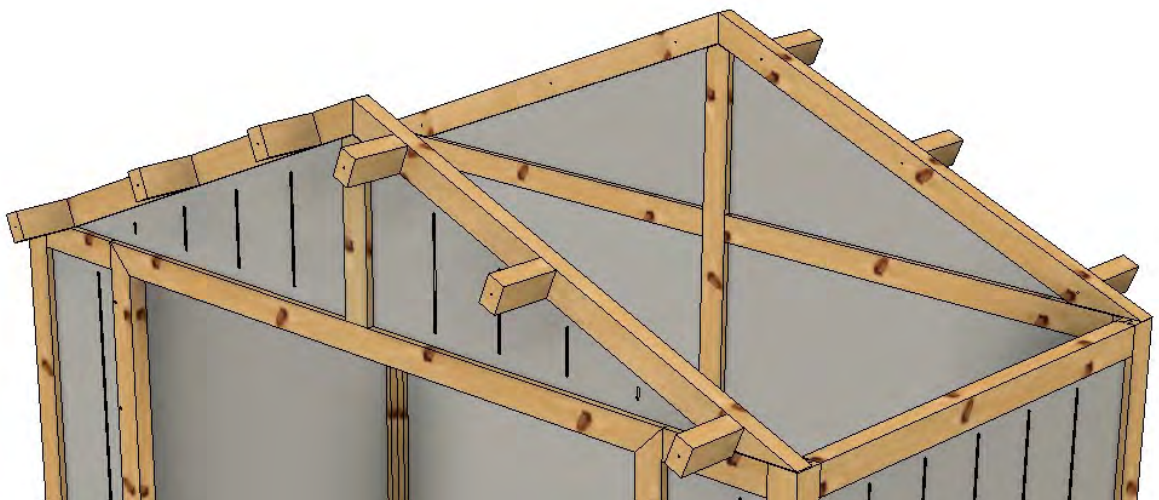
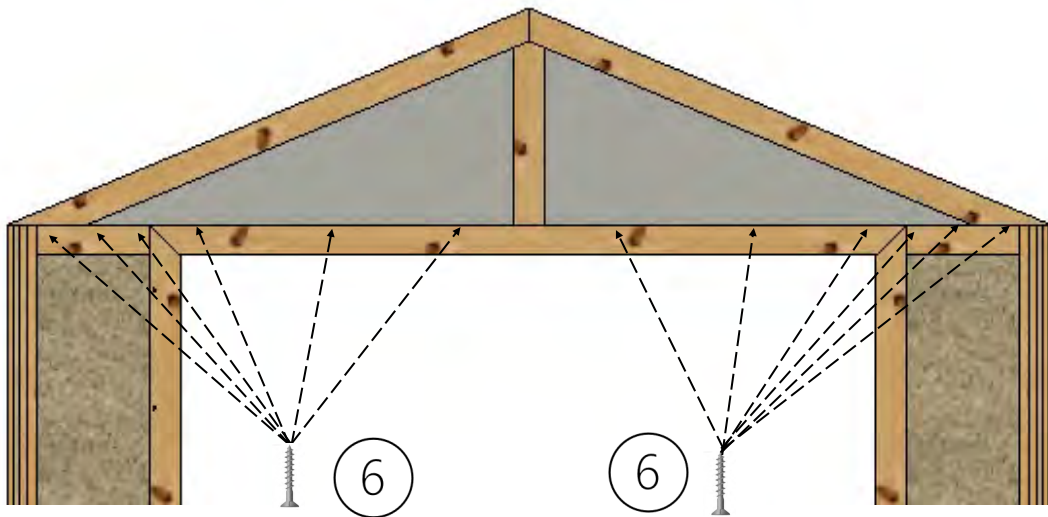
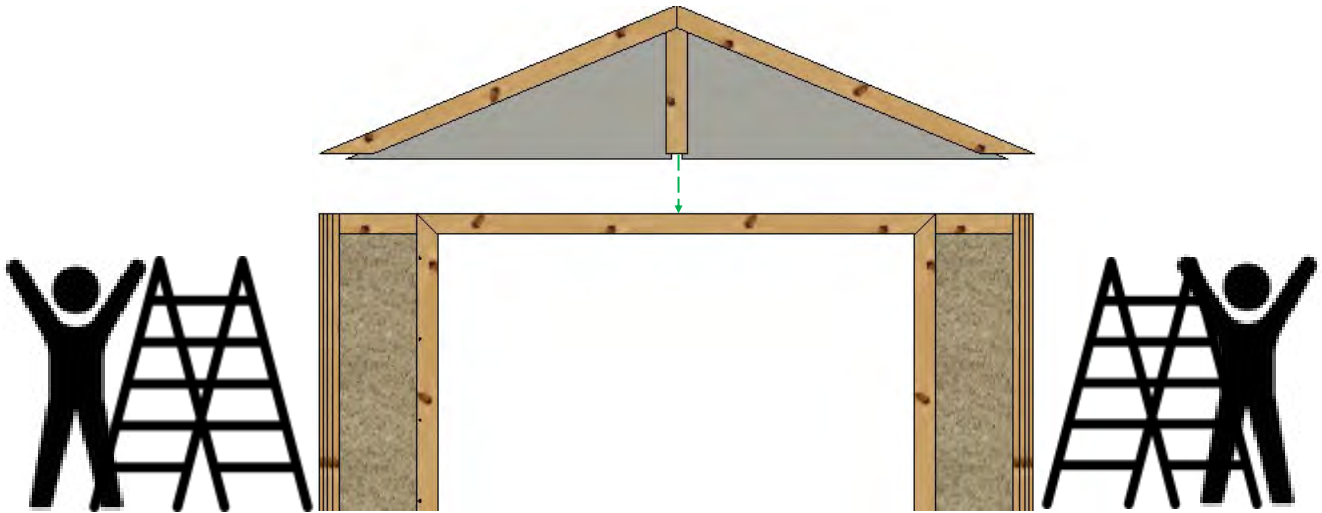
GABLE—Door Side







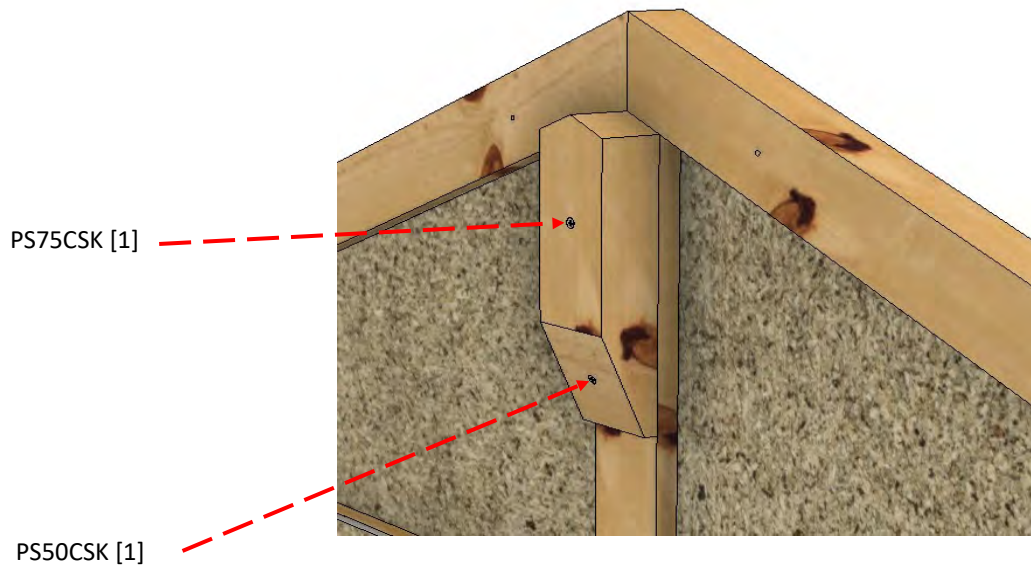
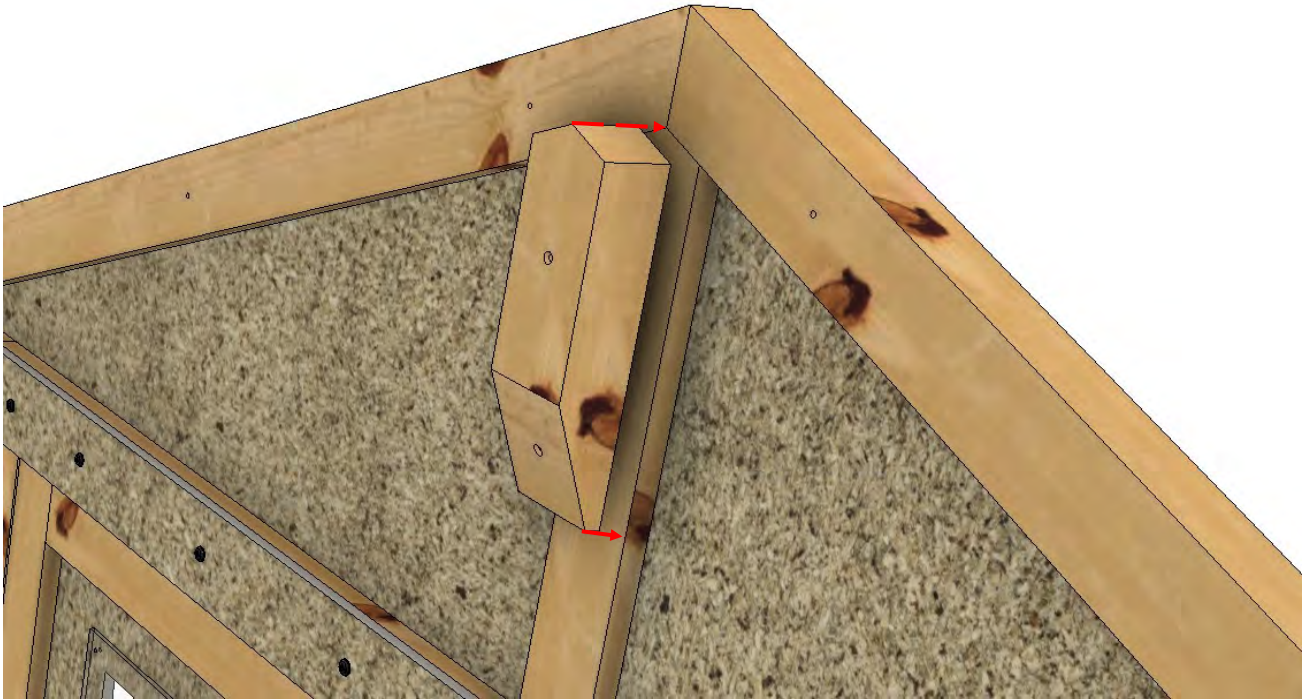





<p>13b</p>	<p>[2]</p>  <p>SB250—Roof Support Block</p>	<p>[2]</p>  <p>PS75CSK—Screw Top fixing</p>	<p>[2]</p>  <p>PS50CSK—Screw Bottom fixing</p>
------------	--	--	---



Fit a Support Block to both Gables

ROOF— Half Roof assembly [2]

14	[8]  REP1735	[8]  RF1135	[4]  LP1906
	[3]  CH1520 MO / SM		[12]  RS1400 MO / SM
	[110]  RS50 MO / SM	[78]  BS75	[36]  RD-AS2 MO / SM

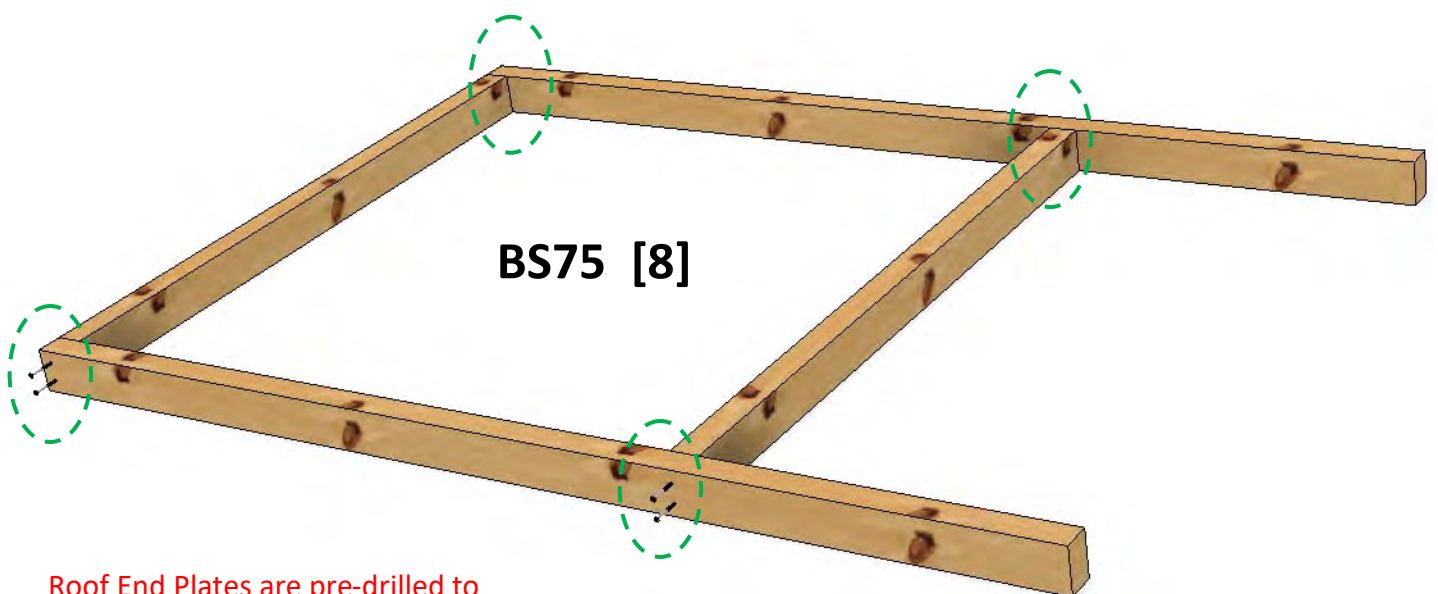
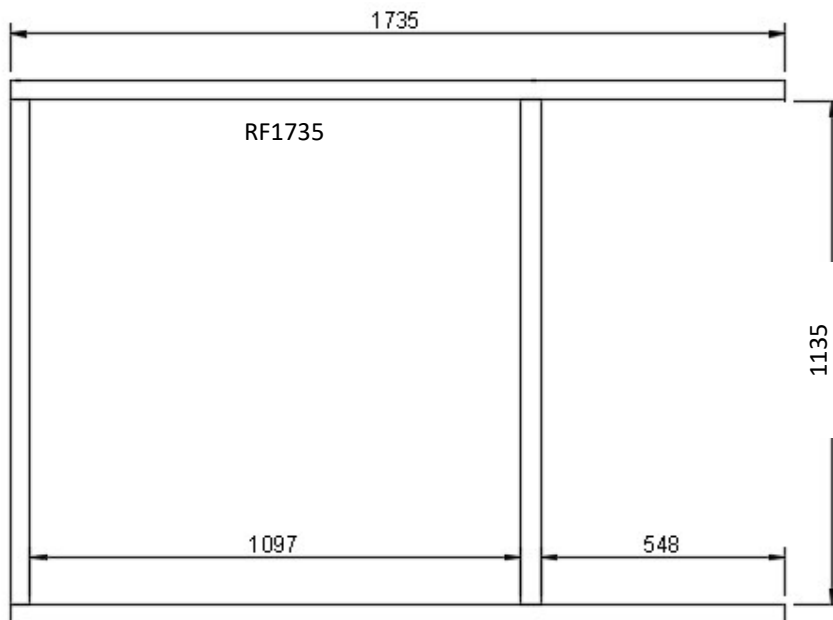

Roof End Plates are pre-drilled to prevent splitting!

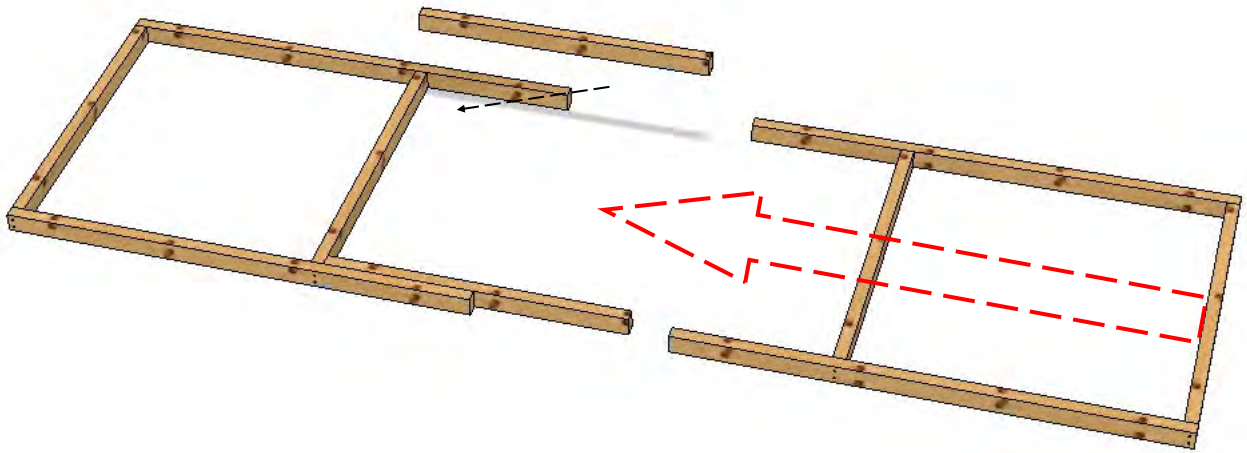

Roof frame overall width is 3470mm

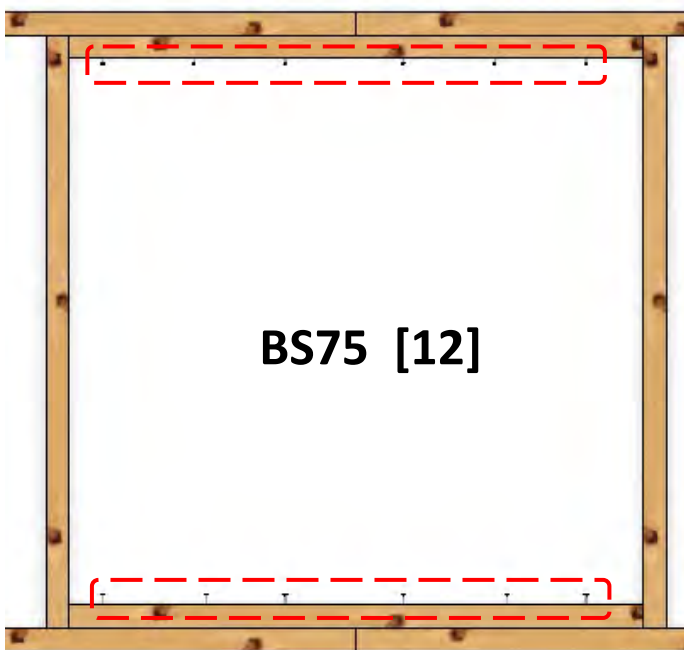
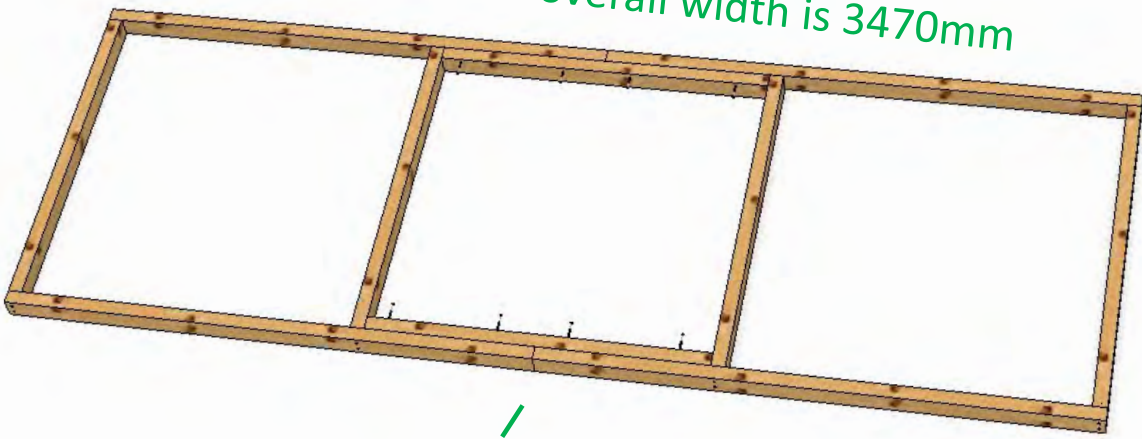

OPTION—INSULATION

If Insulation was specified, it needs to be fitted to the roof frame before attaching the roofing sheets.

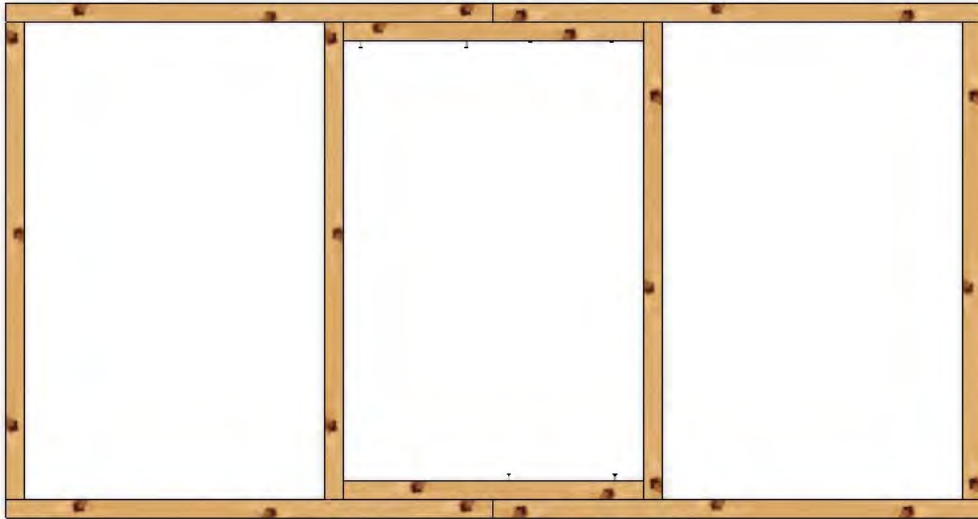

Fix Insulation to Frame with Staples or insulation fixings where indicated (Staples / fixings not supplied).

Ensure fixings are aligned with Frame.

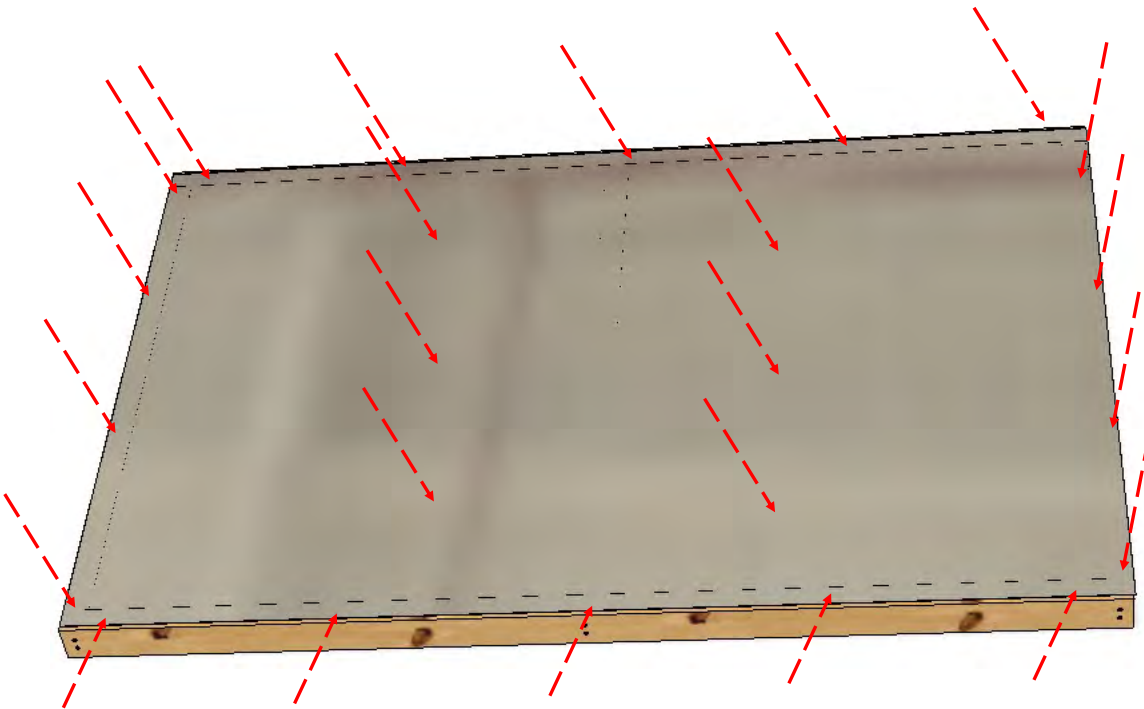

Top of Roof sheet has material folded upwards.

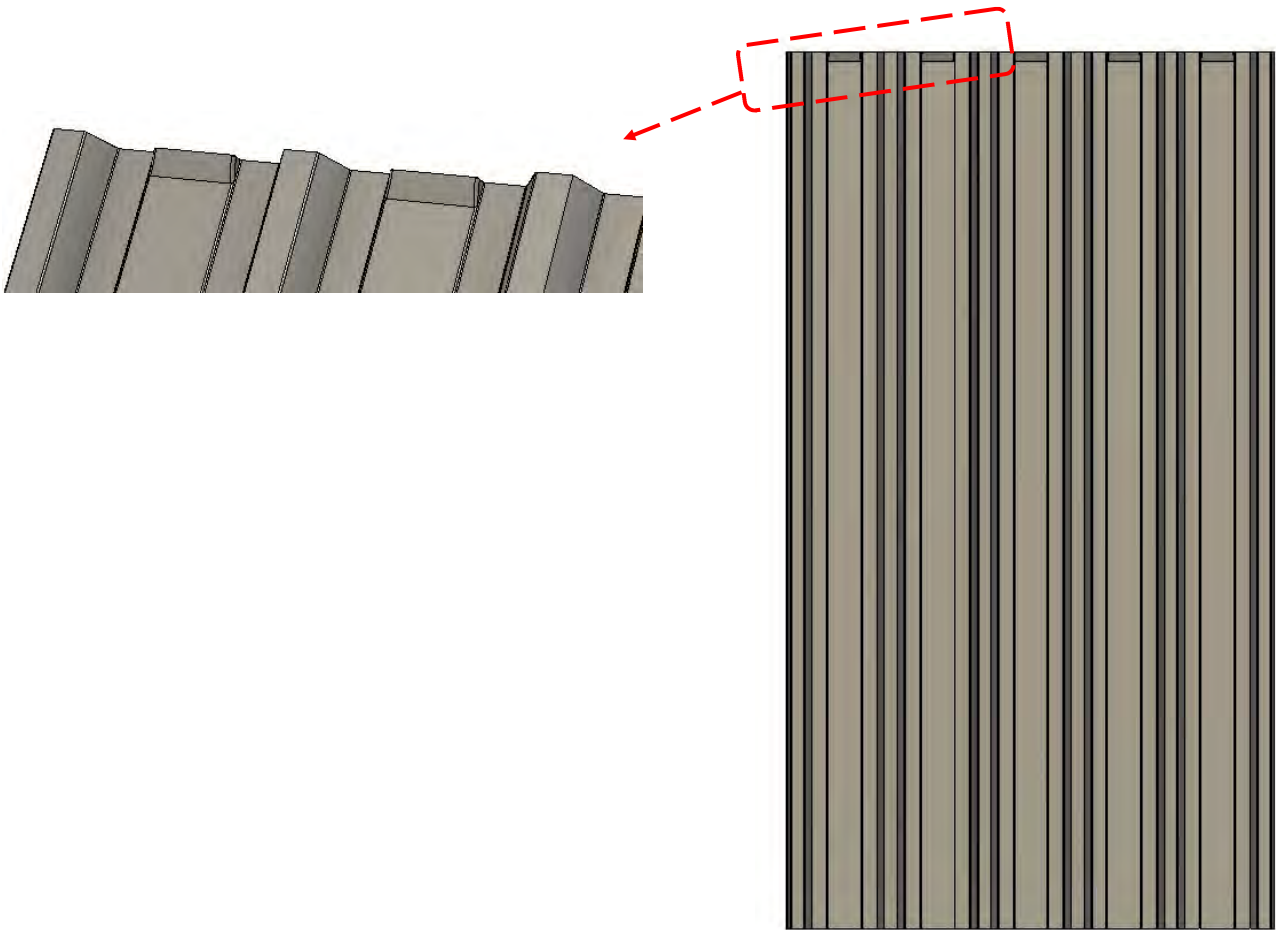

Underside of Roof frame—Distance from sheet to frame edge.

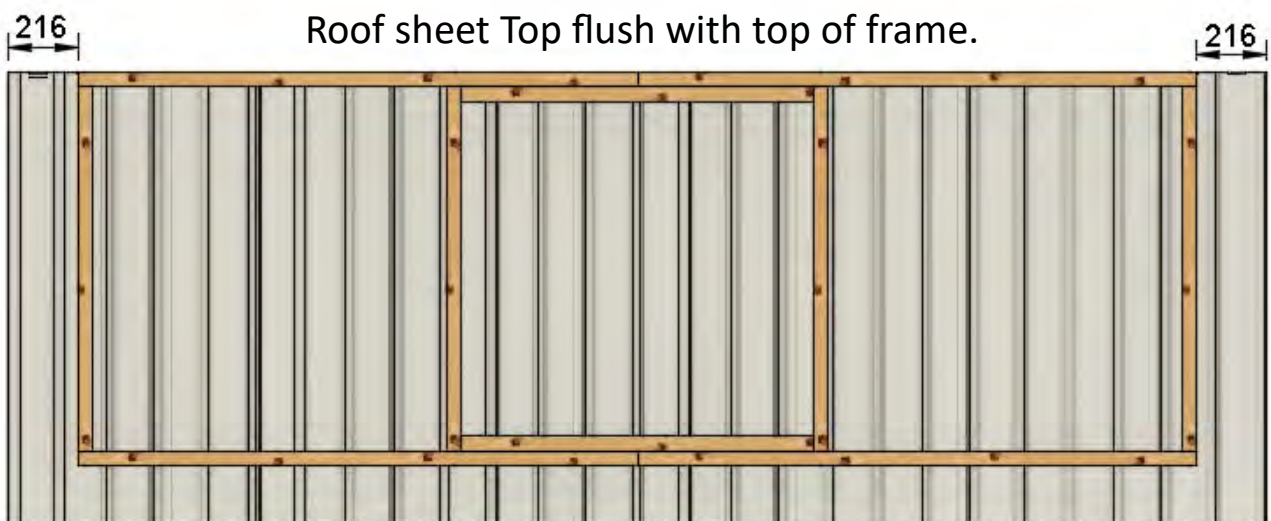

Lay Sheeting on Frame



Sheets 1/2 overlap 1.



Sheets 2/3 overlap 2

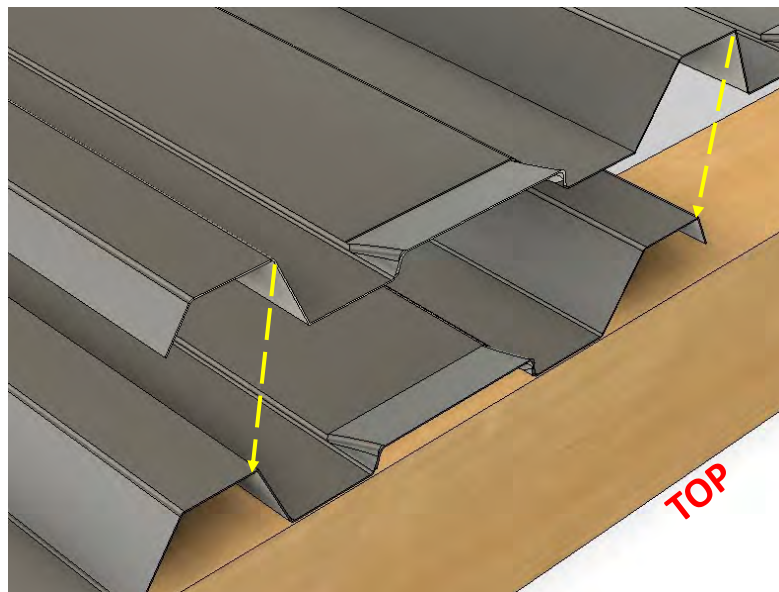

Overlap 2

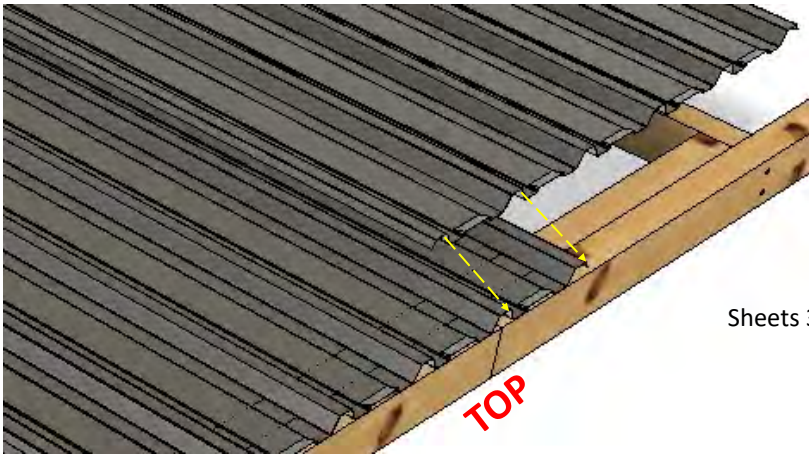

Sheets 3/4 overlap 2

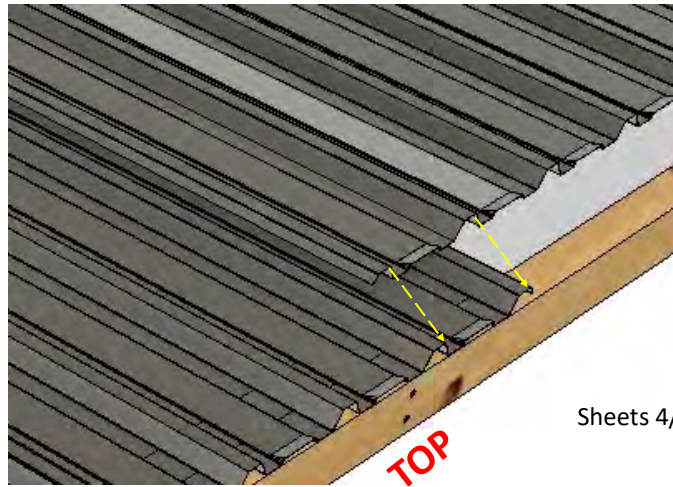

Sheets 4/5 overlap 2



Sheets 5/6 overlap 2

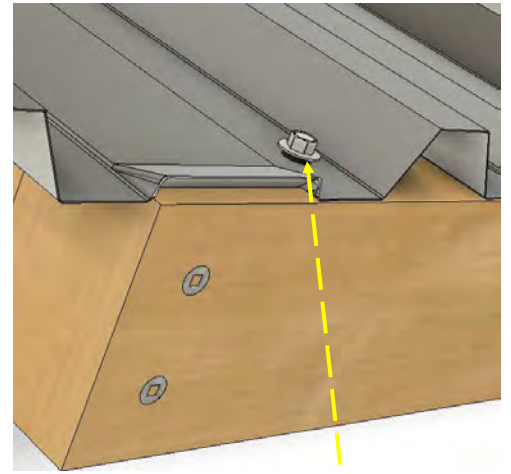
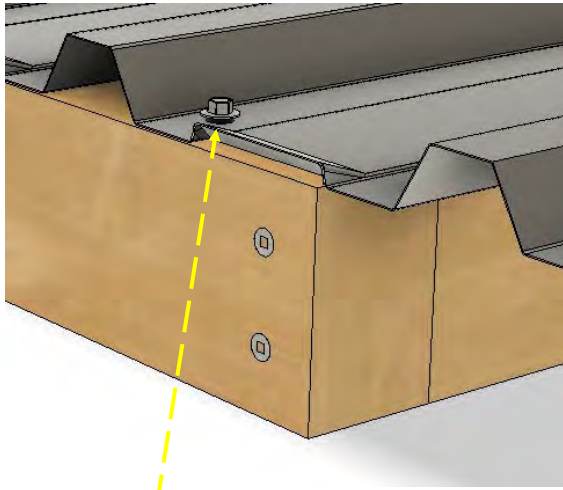

TOP



RS50 MO/SM [4]

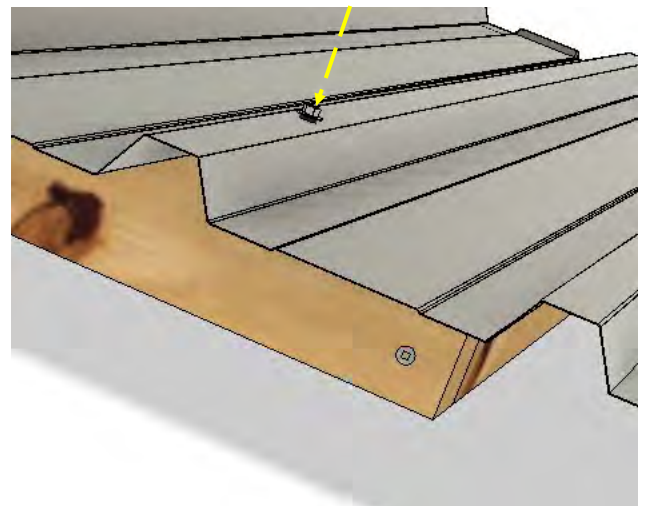
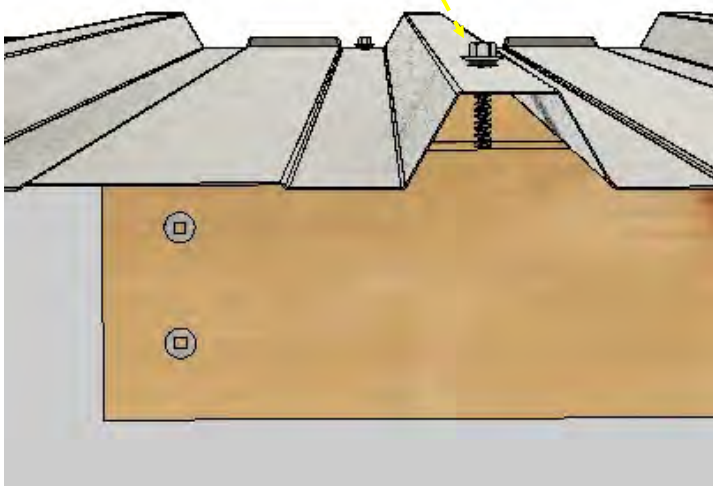

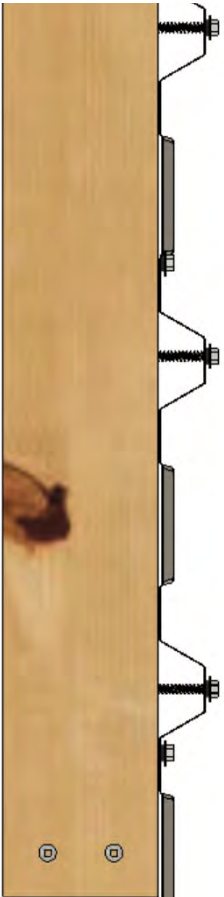

RS50 MO/SM [21]

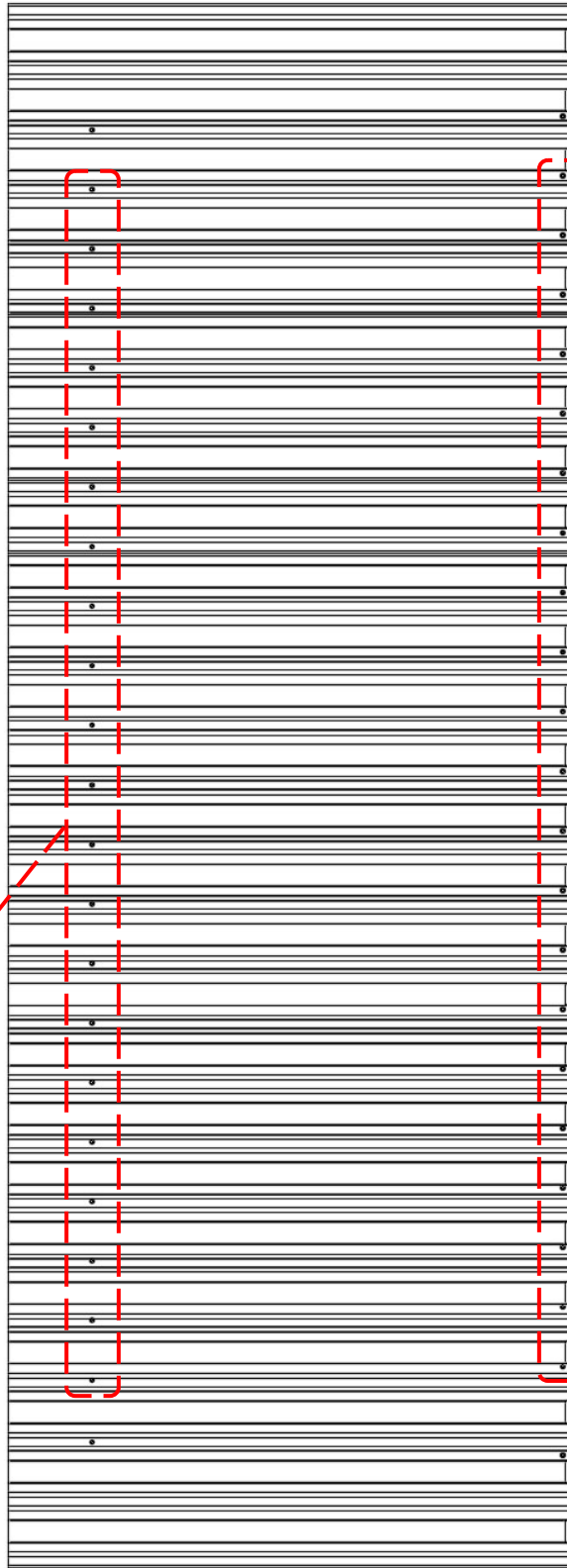

TOP

RS50 MO/SM [21]

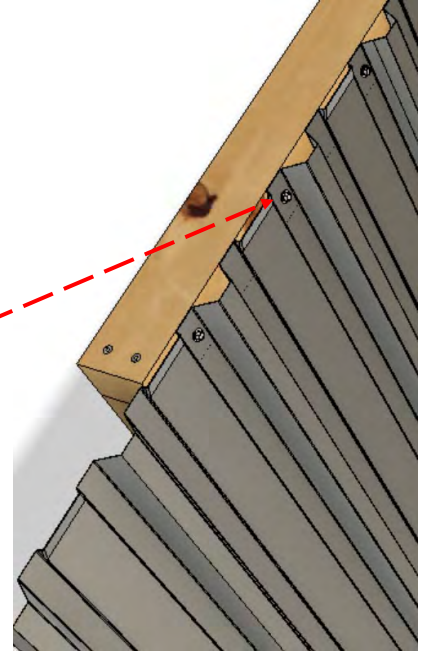

End Frame Fixings

RS50 MO/SM [3] x2



Lower Roof Screws placed in Peaks of Sheet.
Do not Overtighten.

End Fixings placed in Valley nearest to end of Frame.

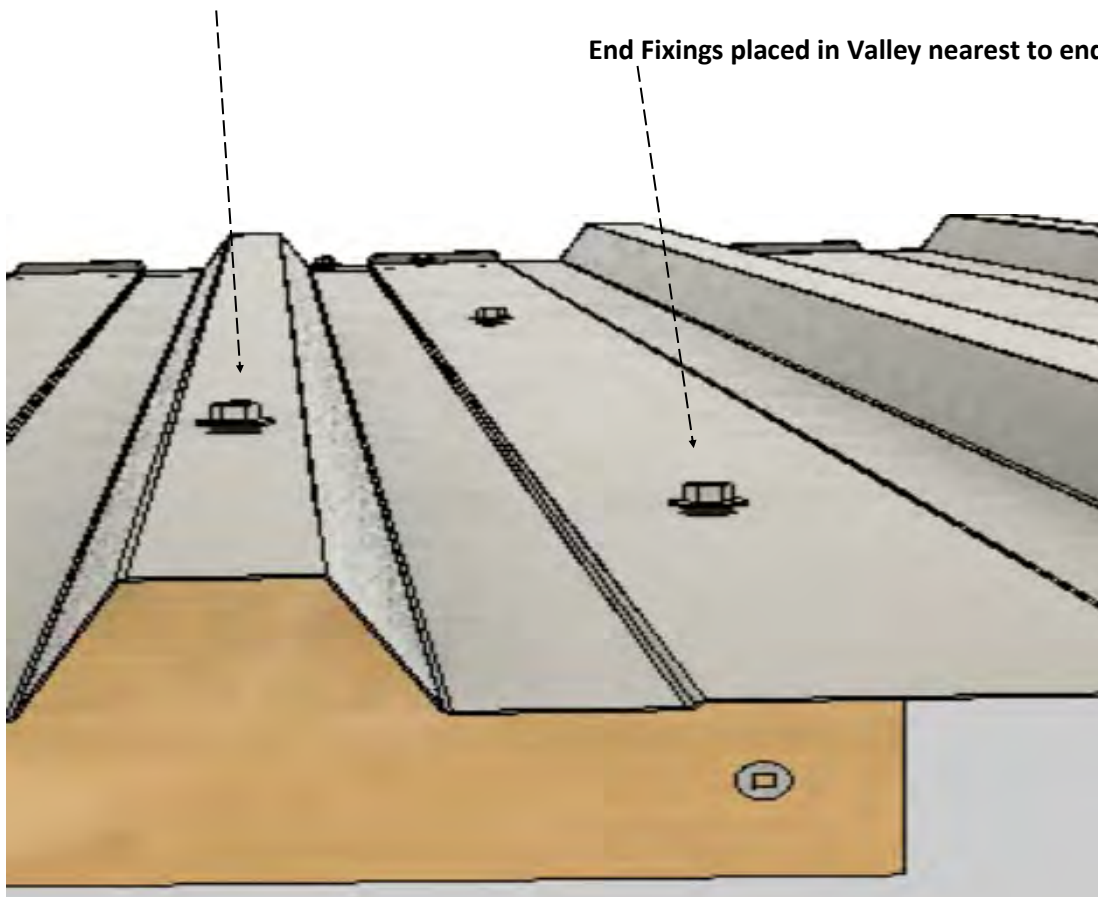

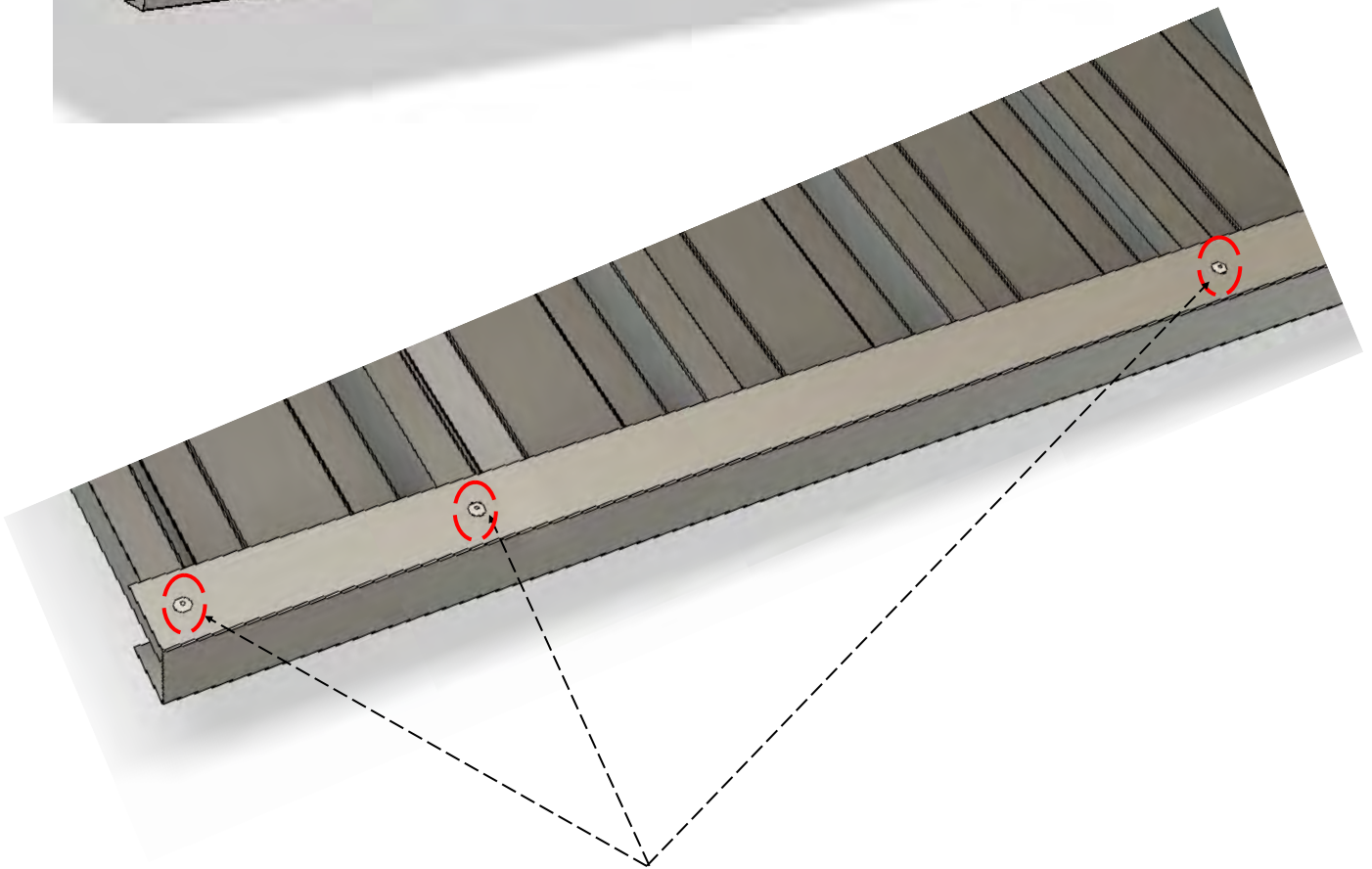
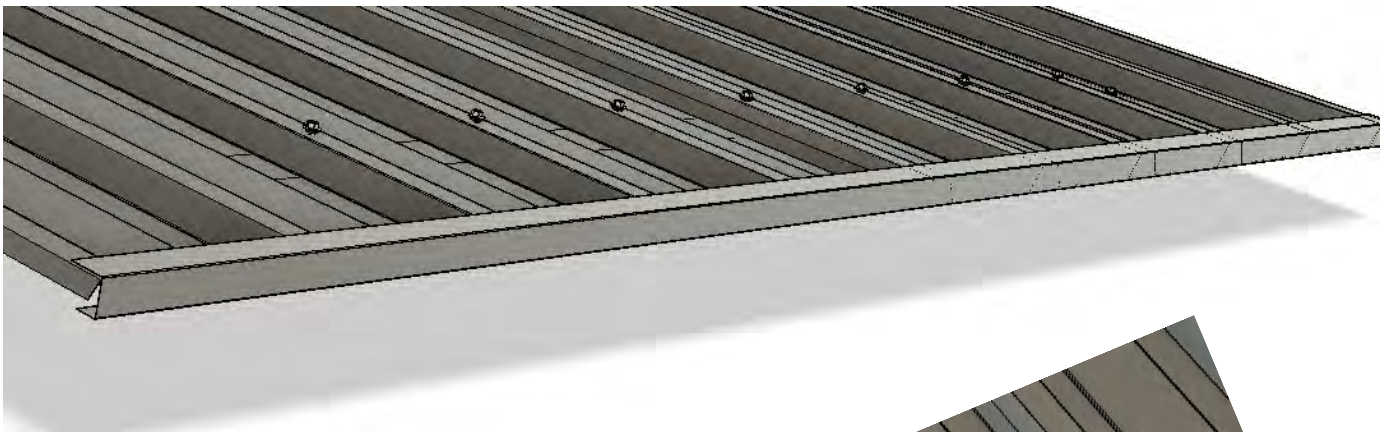
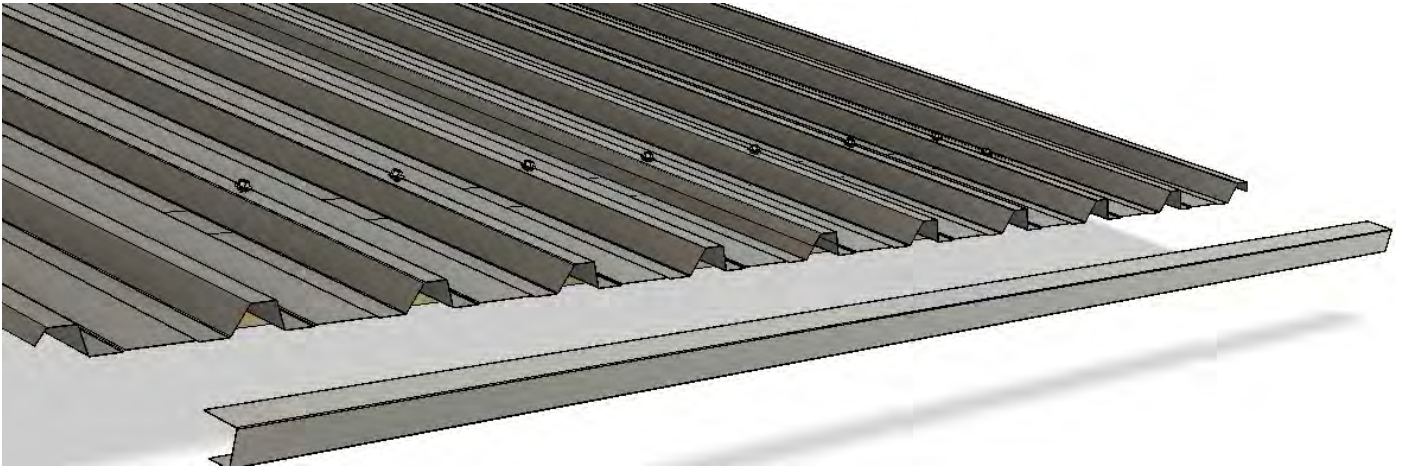



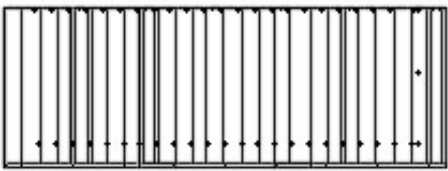

RD-AS2 MO / SM [11]

**1st & 2nd Peaks then 3 Peak Spaces then Penultimate
and Last Peak.**

Roof Assembly—Installation

<p>15</p>	<p>[2] Half roof Assembly</p> 	<p>[2] CT-A</p>  <p>[12] PS50SK</p> 	<p>[20] BS75</p>  <p>[8] BS125</p> 
-----------	---	--	---

Slide 1st Roof assembly onto the shed.

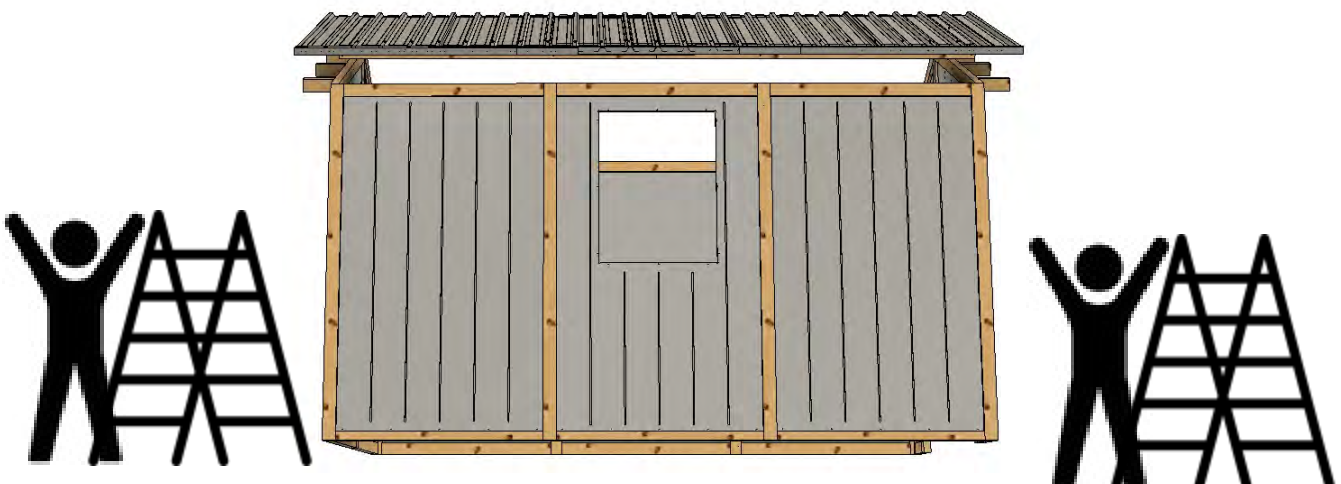
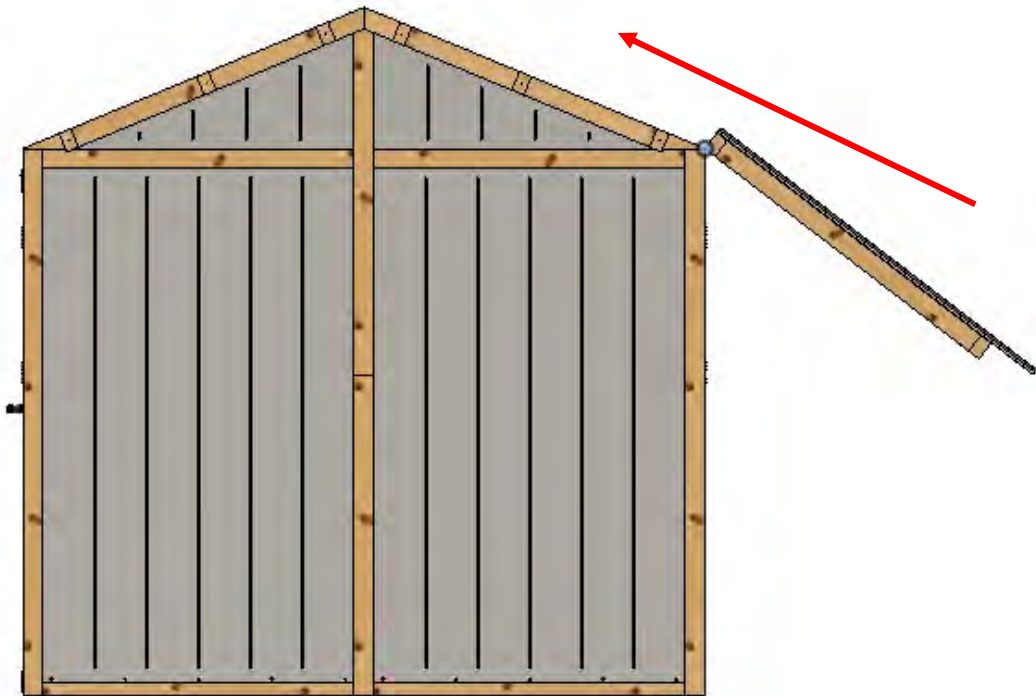

Align edge of roof frame on apex of Support Block and Gable

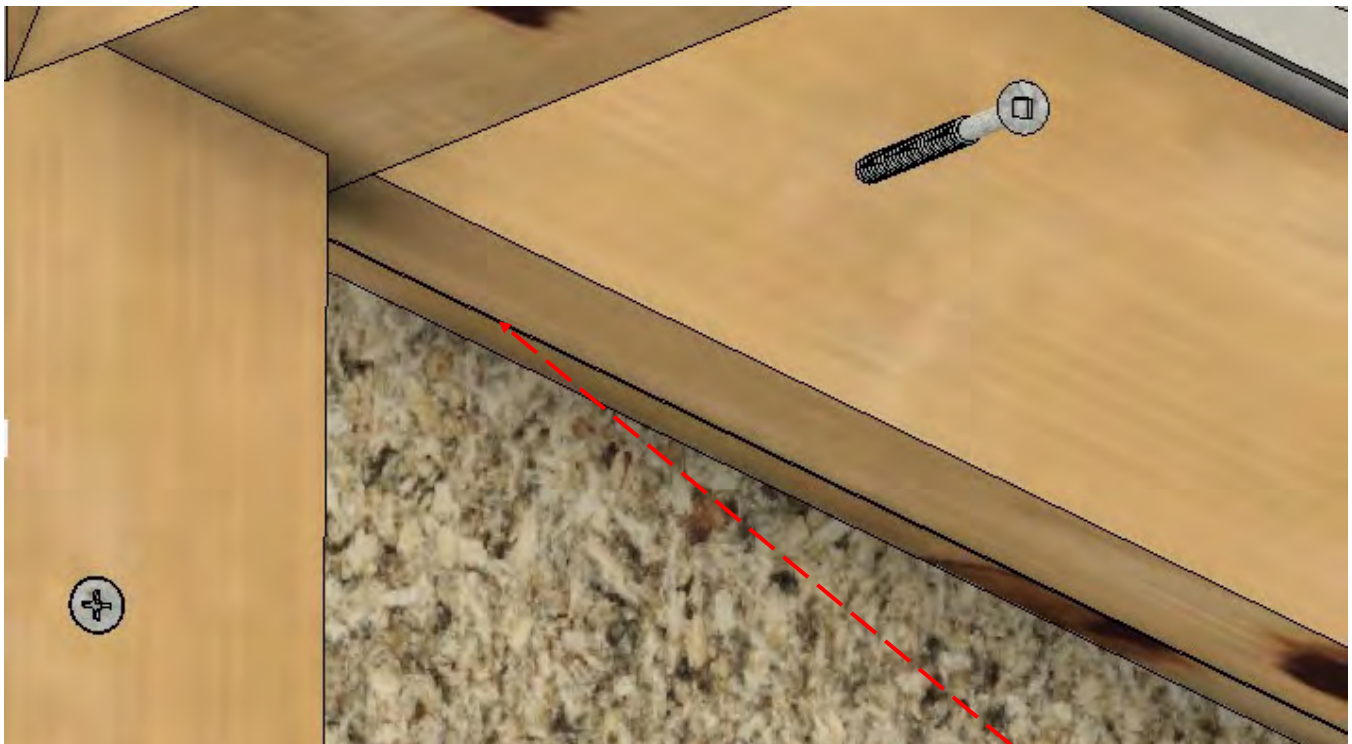
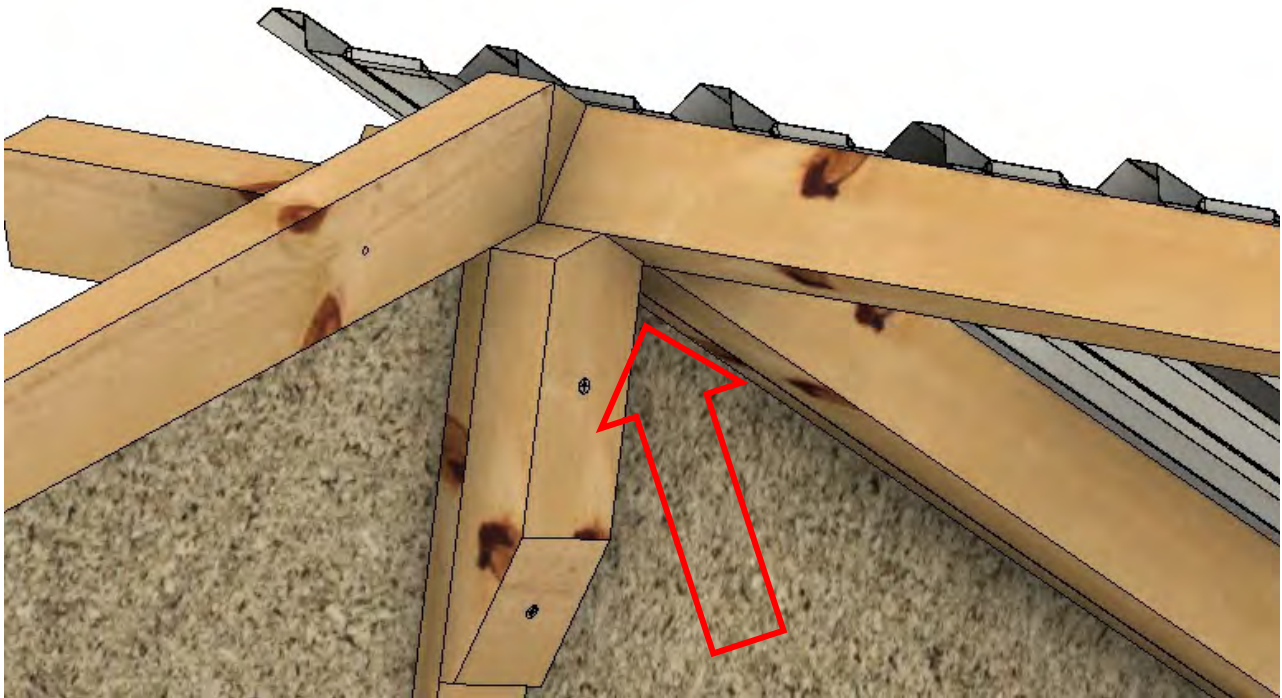

Align Base of Roof frame with
Bottom of Gable Frame

Fix 1st Roof panel to Gables
before fitting remaining roof
panel. 6 x BS75

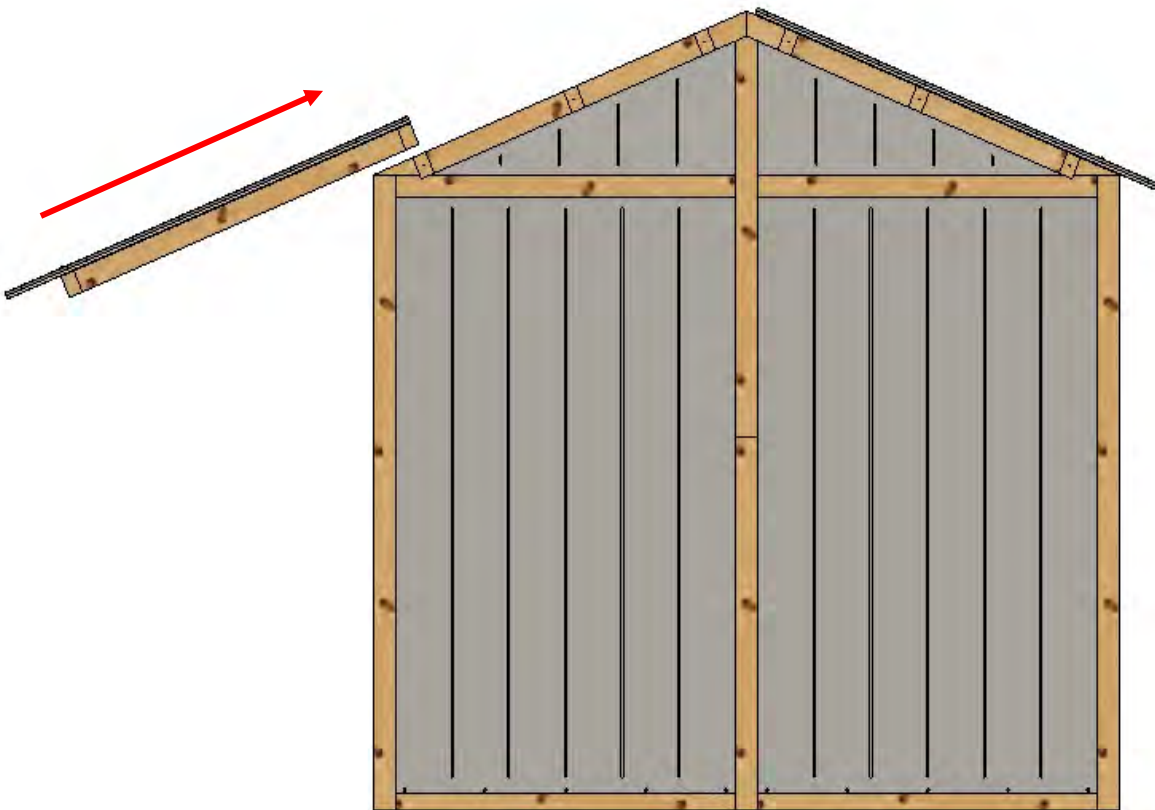
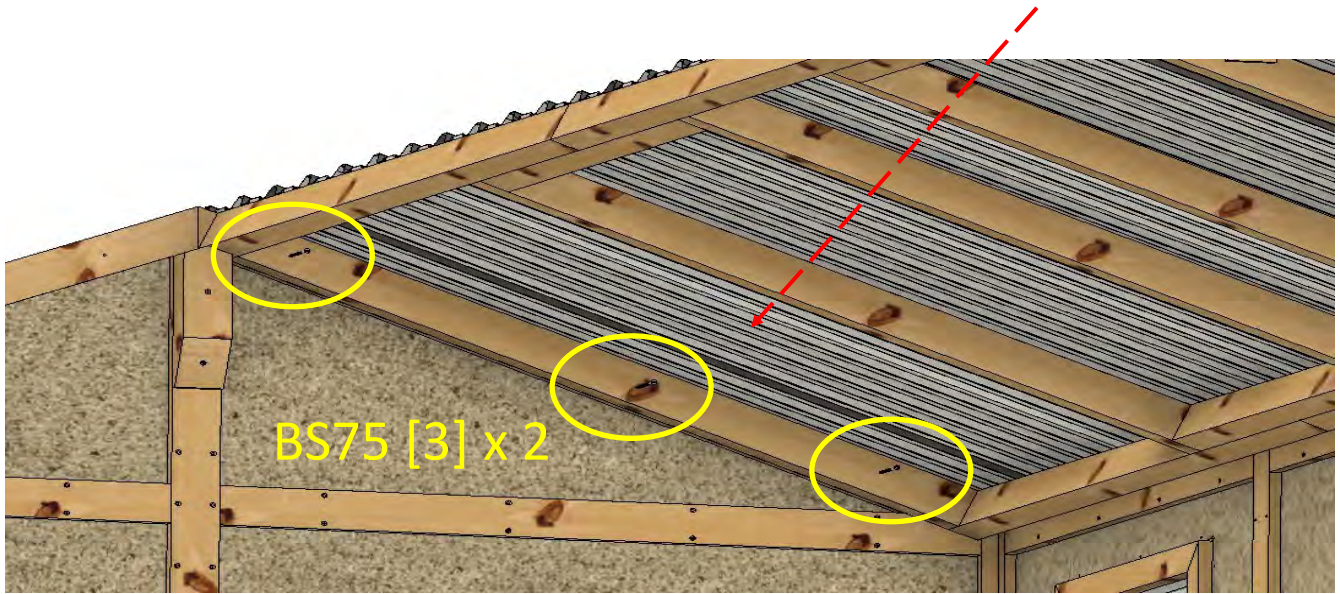

Once the first roof panel is secured into the gables slide the other roof panel up into the corresponding gable gap.

Butt Roof Frames to Apex of Support block.

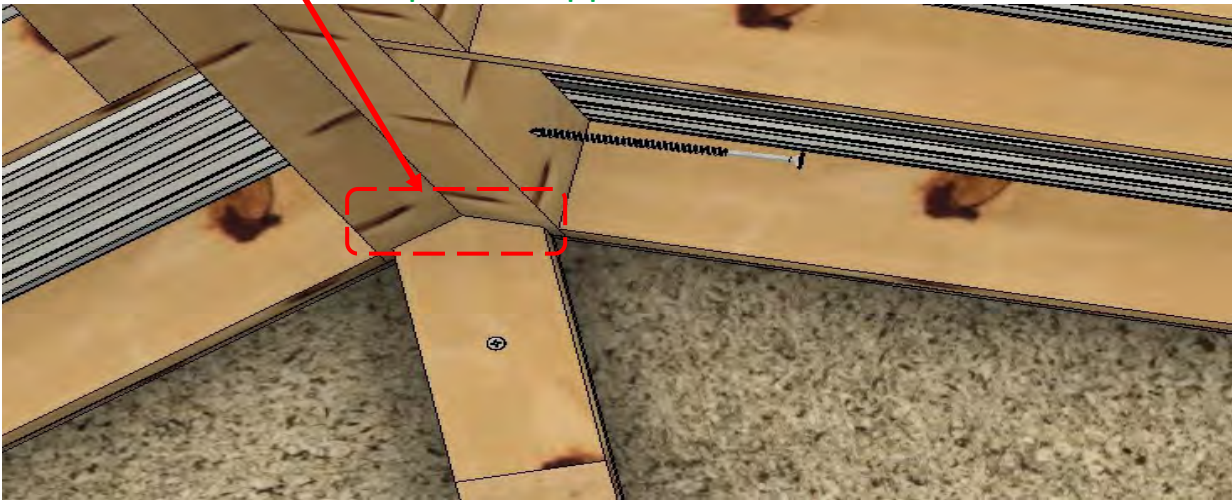

Secure 2nd frame to gables. Using BS75 [3] x 2

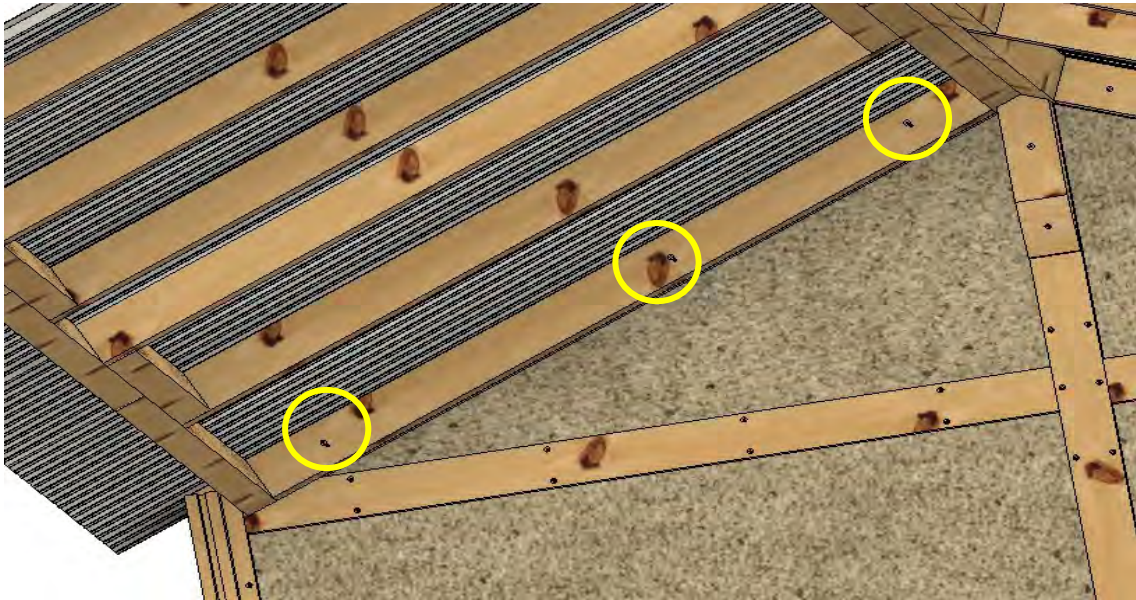

Fasten top of Roof Frames with BS125 [4].

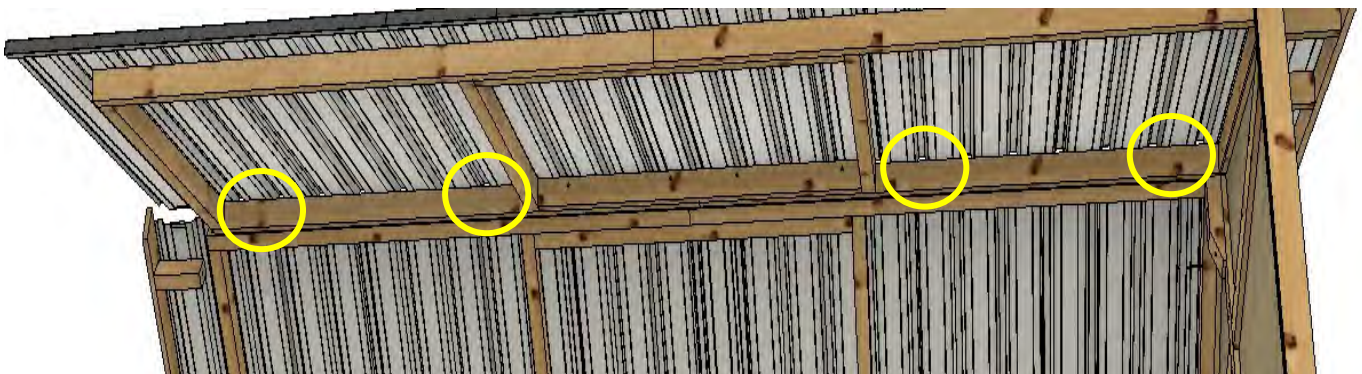

Roof Assembly—Side Wall fixings



Fixings to be added to both side walls as above.

Roof Frame



Long Wall

BS75 [2]

BS125 [2]

BS75 [2]

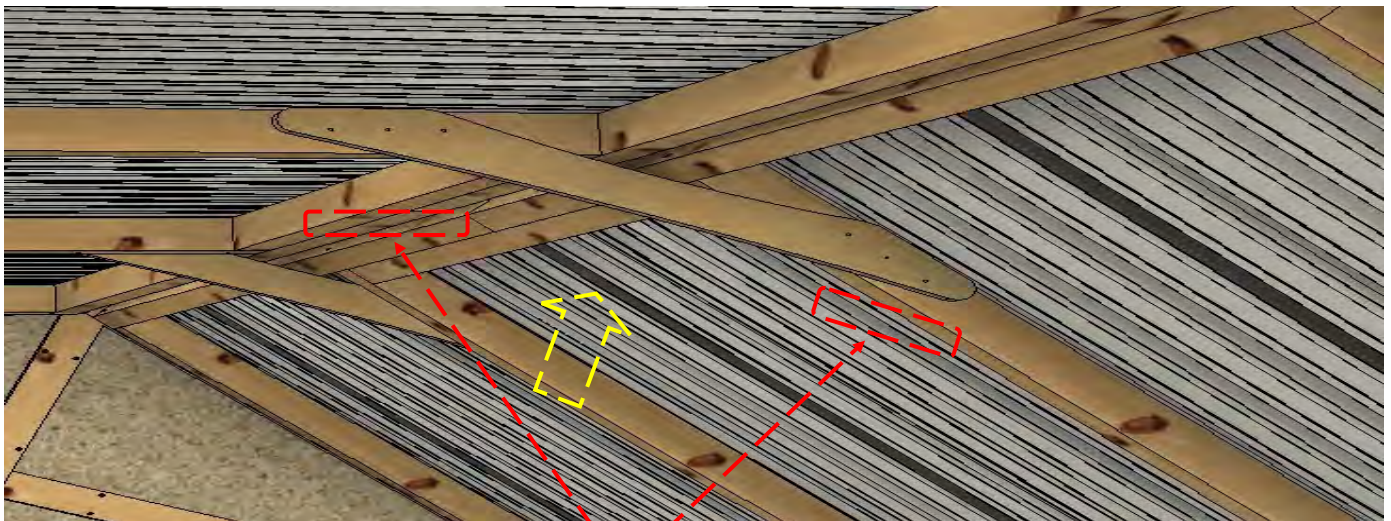

BS125 used in centre through joining plate into top of wall.

Collar Tie.



PS50CSK [6]

Gable assembly

<p>16</p>	<p>[4]</p>  <p>F1500</p>	<p>[24]</p>  <p>PS32CSK</p>
-----------	---	--

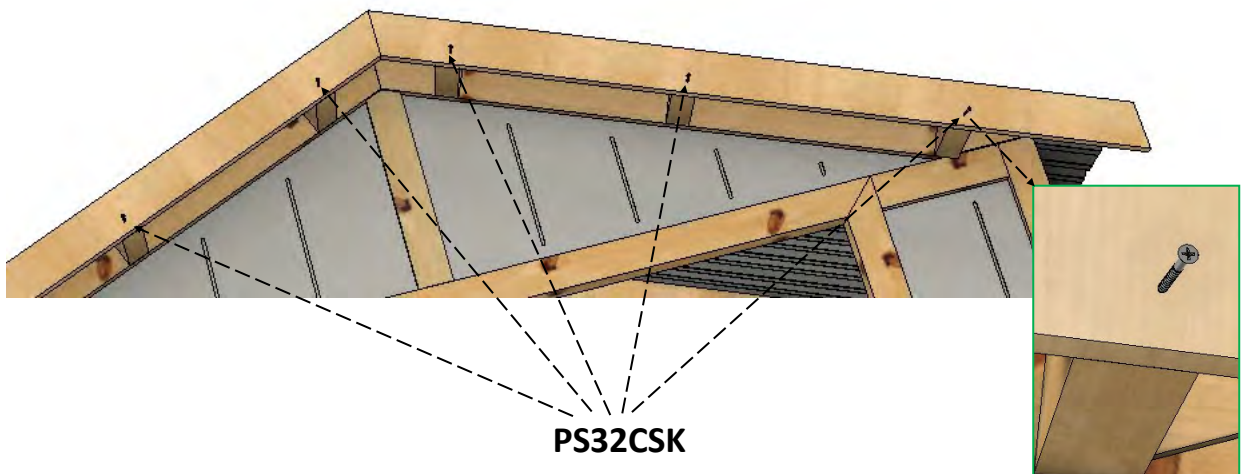
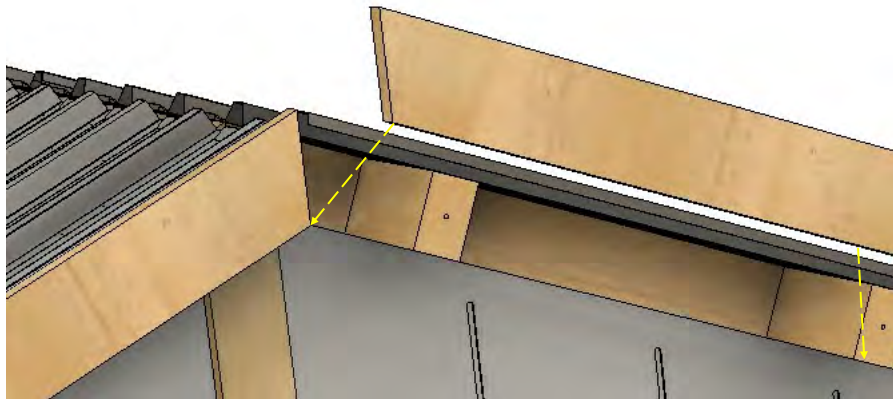
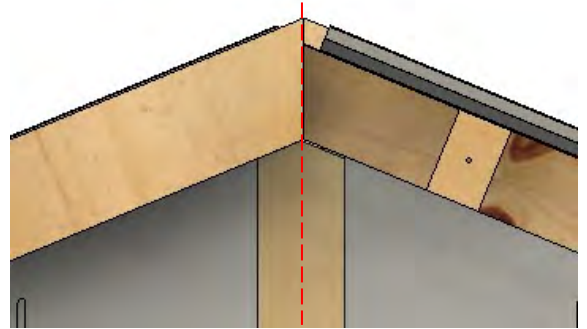
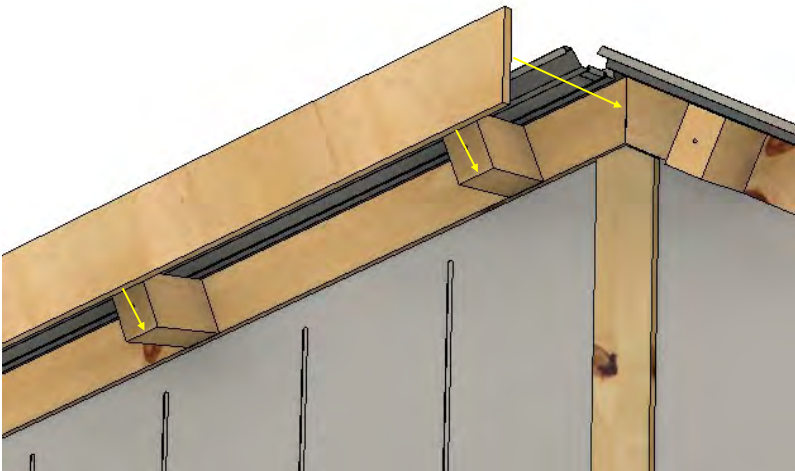

Ridge Cap

17	[3]  RC1520 MO/SM	[8]  RS50 MO/SM
---	---	---

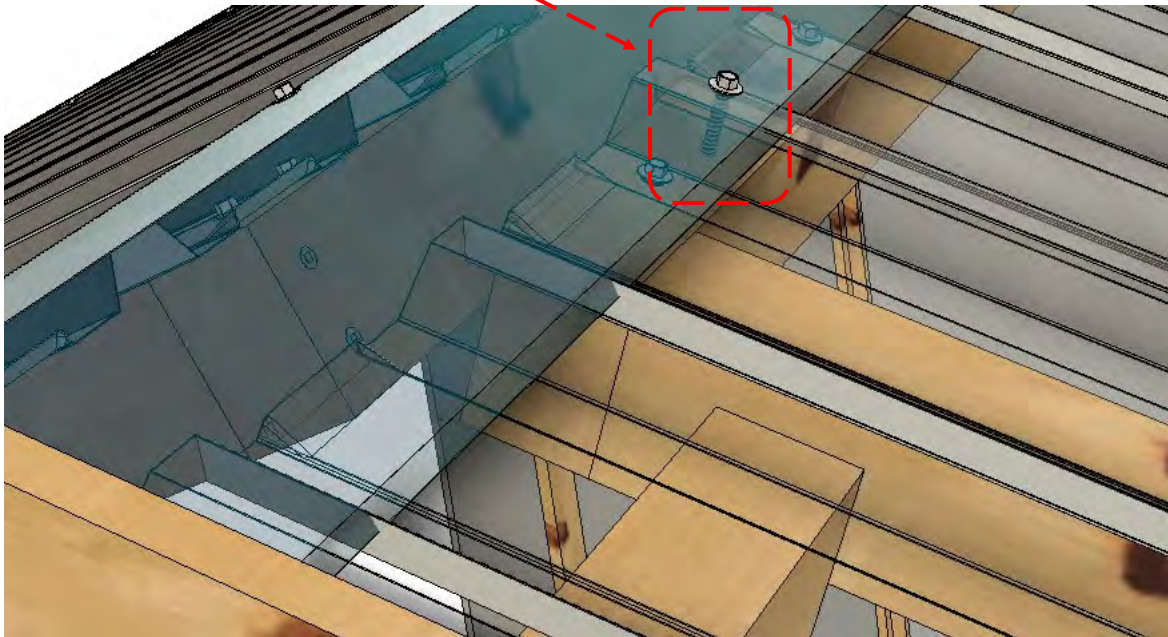
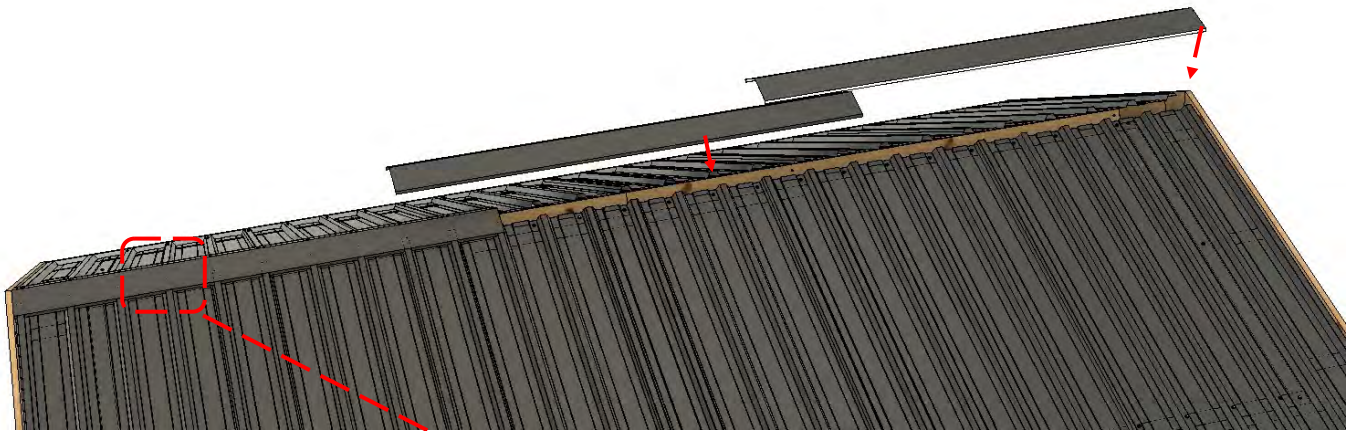

Remove Protective film from painted face of Ridge Caps. Place ridge caps into position carefully, avoid dragging or scratching.

Make sure peak of ridge cap is in line with peak of fascia's. Screw through ridge cap into 3rdnd and 10th Ribs, from each end of the roof. Drive these screws through and into roof frame.

RS50 MO/SM [8]

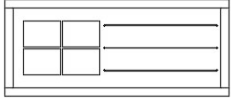

Door Hanging

18	[2]  Door Assy [L & R]	[2]  TH150B
----	---	--

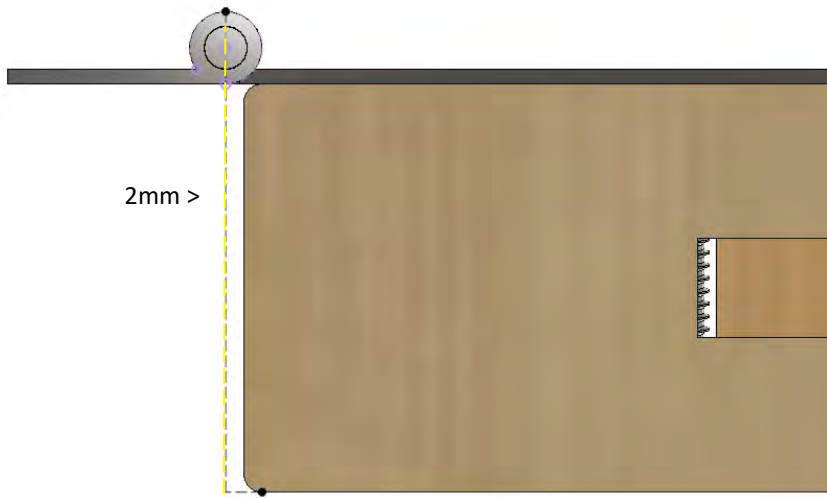
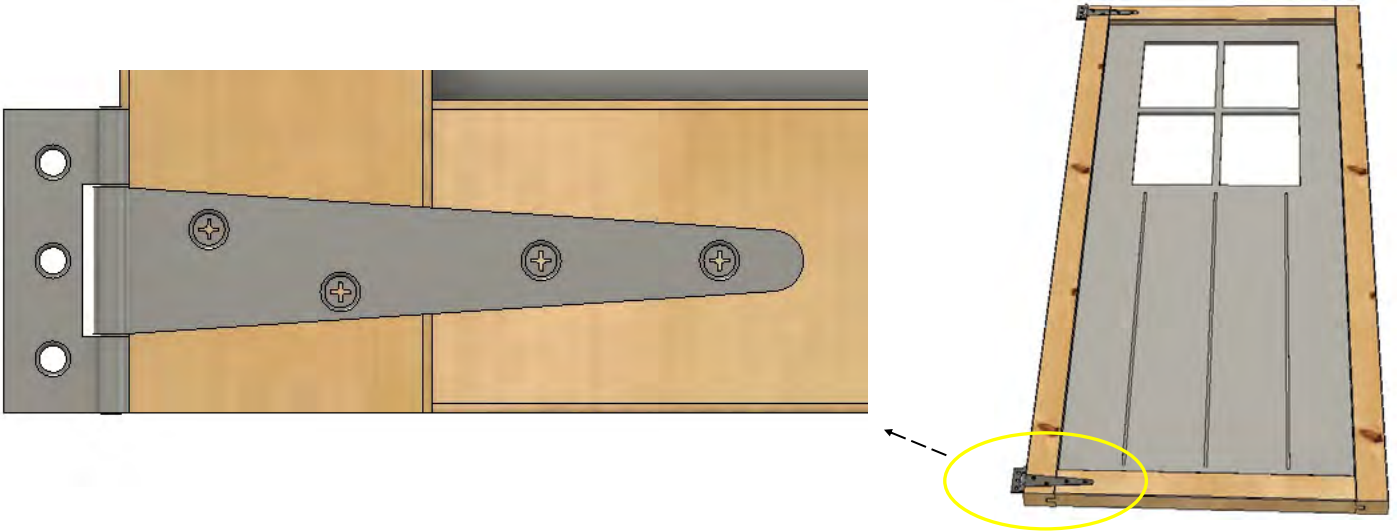

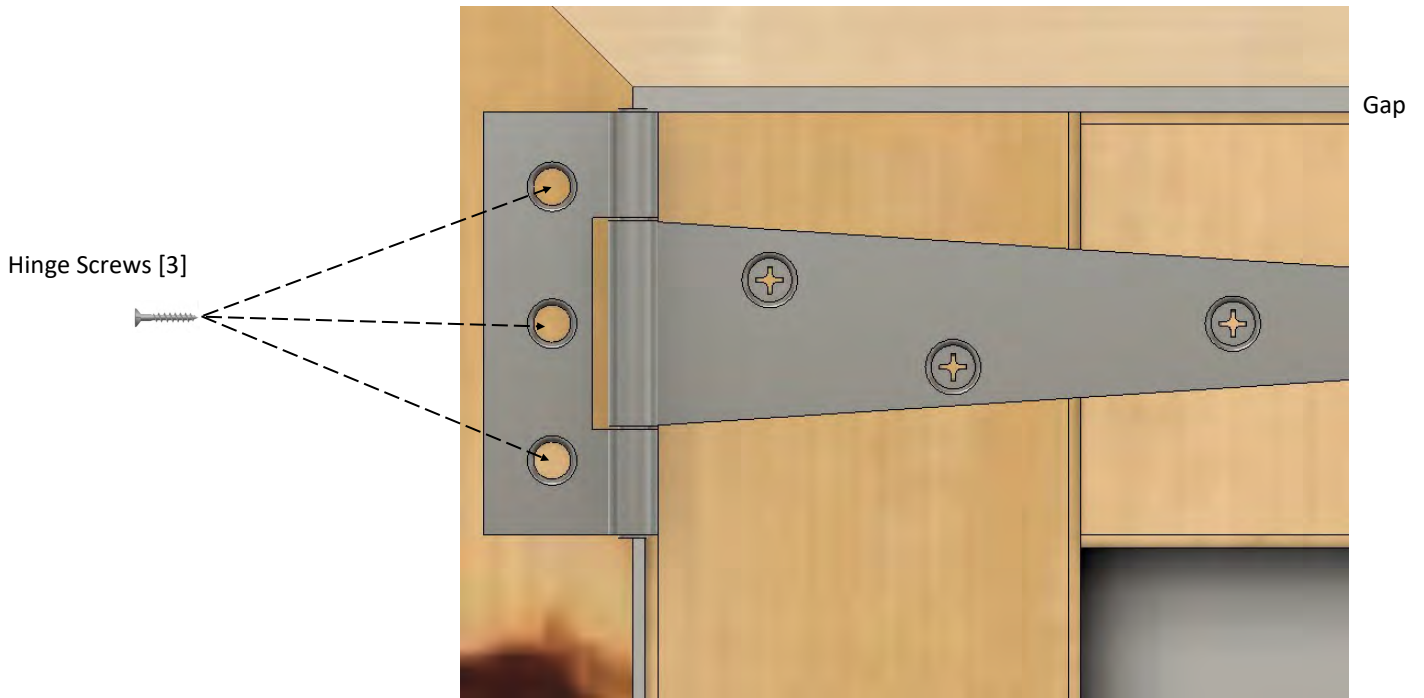

Left Hand shown—Right Mirrored.



Top Hinge Shown—Bottom similar.

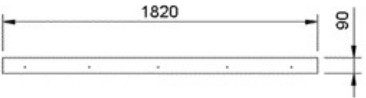
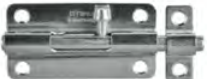

Door Furniture

<div data-bbox="167 318 258 407" data-label="Text"> <p>19</p> </div>	<div data-bbox="316 219 347 246" data-label="Text"> <p>[1]</p> </div>  <div data-bbox="470 488 614 515" data-label="Text"> <p>DS1820x90 [</p> </div>	<div data-bbox="782 219 813 246" data-label="Text"> <p>[2]</p> </div>  <div data-bbox="909 324 997 351" data-label="Text"> <p>BB100S</p> </div>	<div data-bbox="1141 219 1173 246" data-label="Text"> <p>[1]</p> </div>  <div data-bbox="1220 436 1412 463" data-label="Text"> <p>THB [Fixings Kit]</p> </div>
	<div data-bbox="782 380 813 407" data-label="Text"> <p>[8]</p> </div>  <div data-bbox="877 488 1029 515" data-label="Text"> <p>FB20 MO/SM</p> </div>		

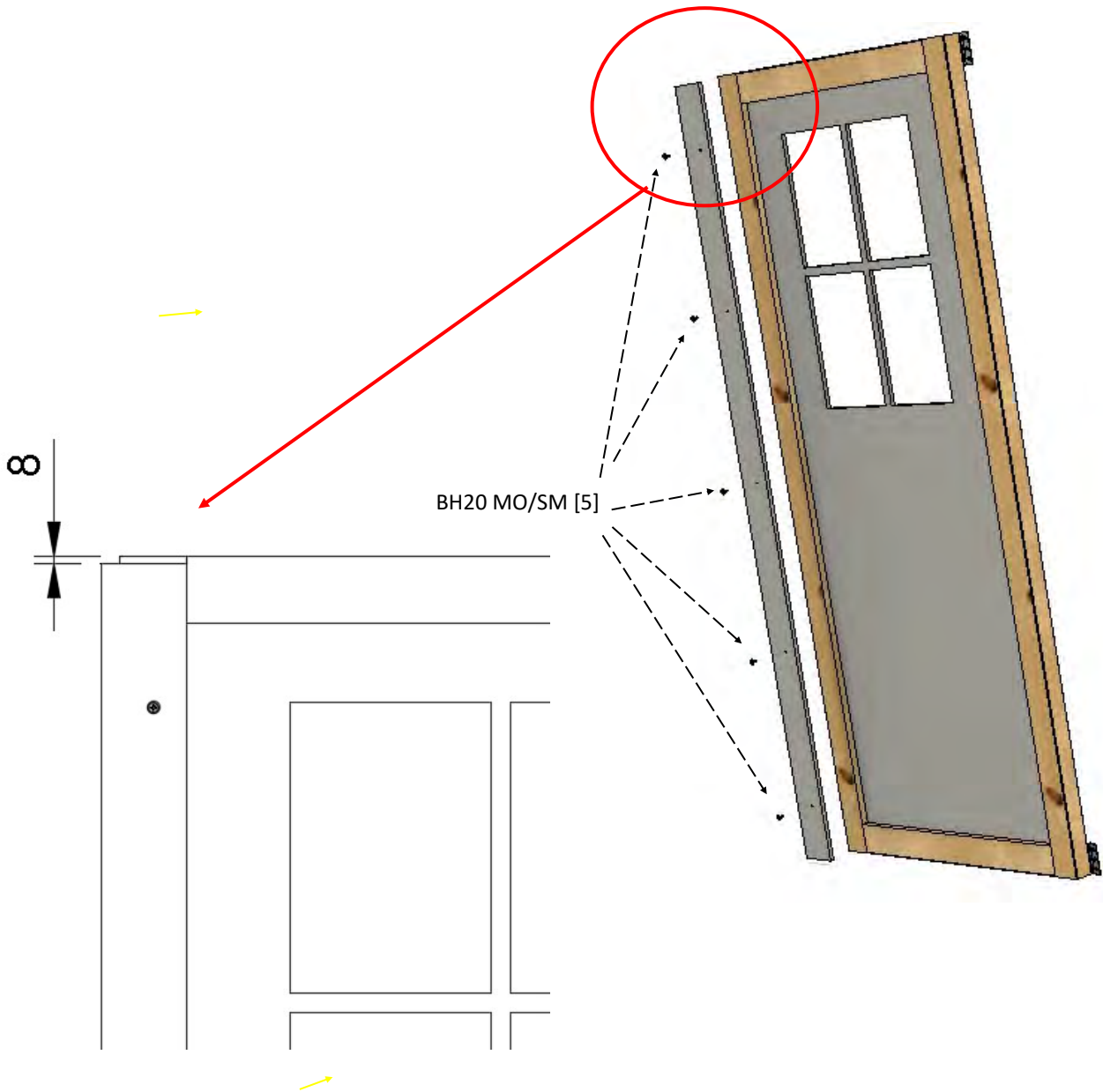

Upper Drop Bolt

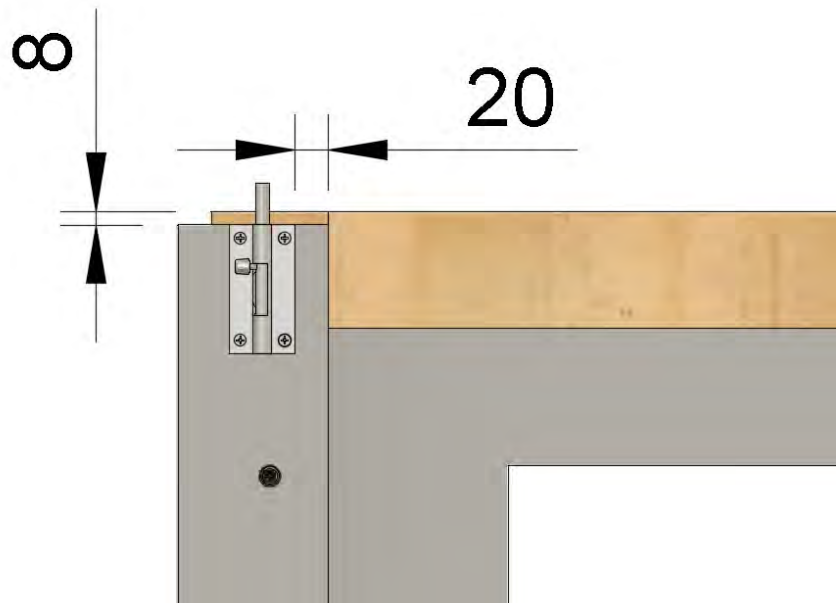

Lower Drop Bolt

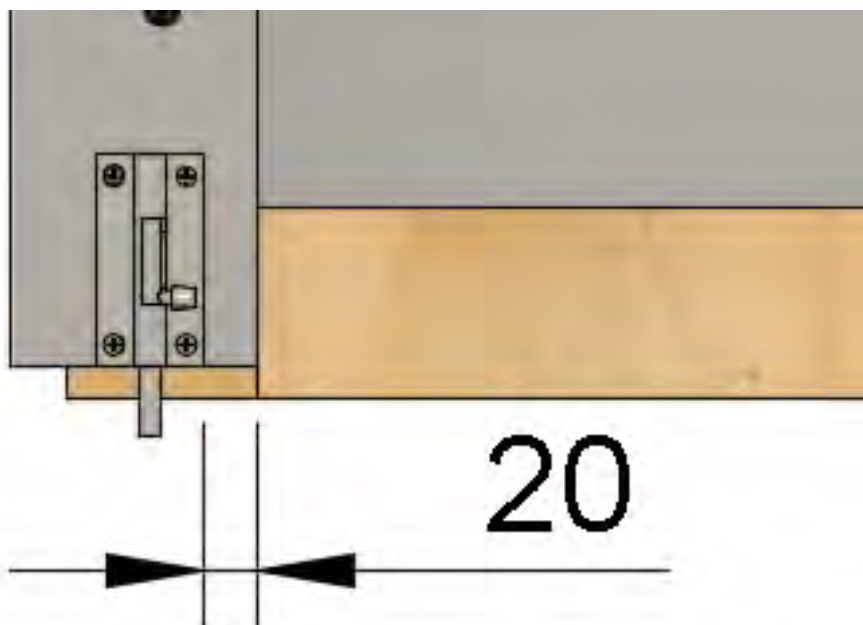

Side Door Stops, position

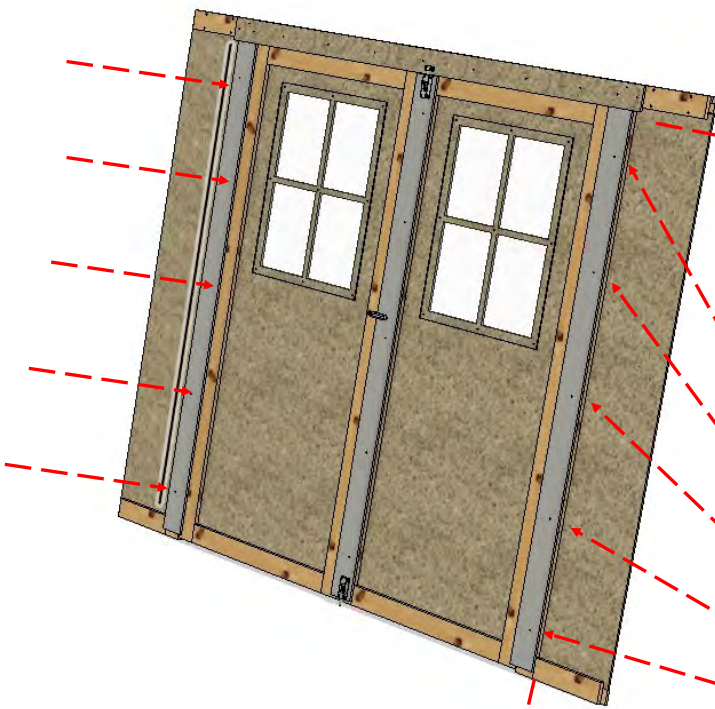
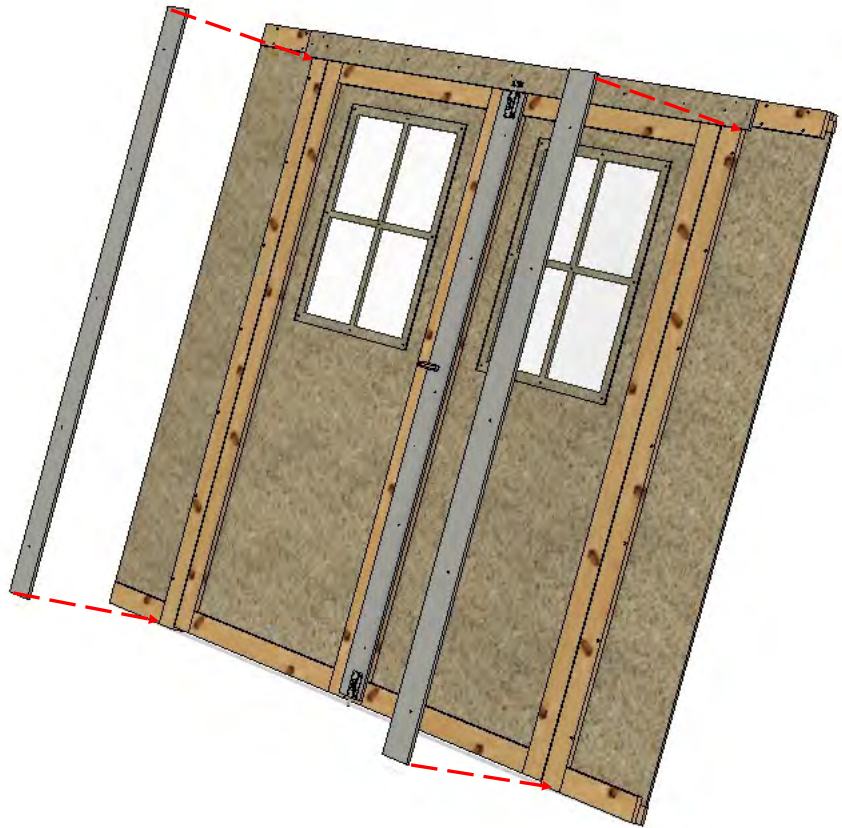

BH20—5 per DS1820

Lock Position



12mm and 2 x 6mm

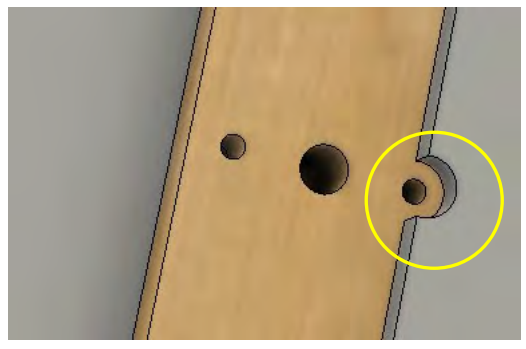
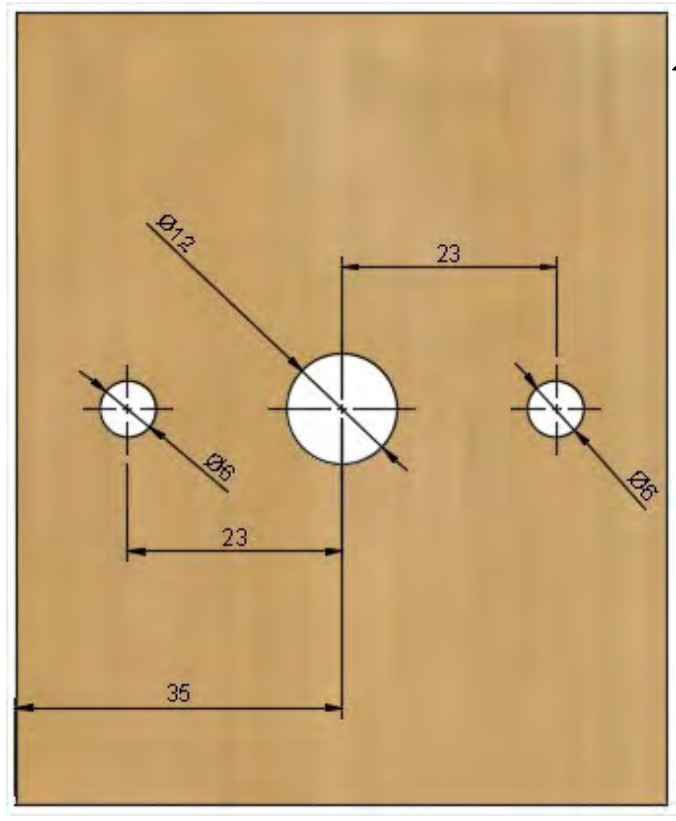
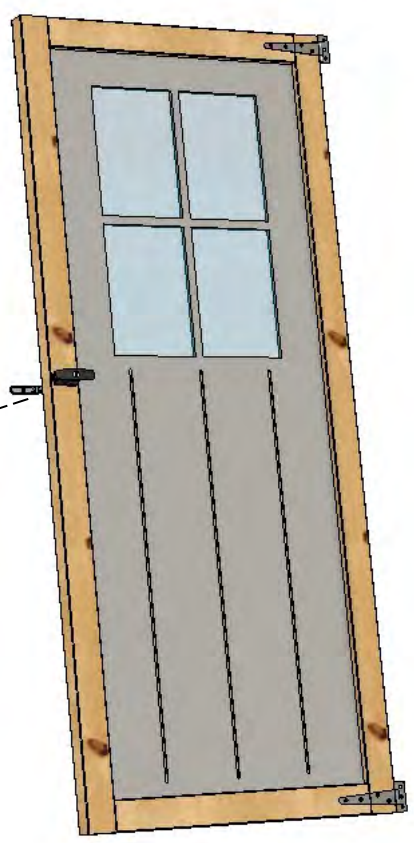

Note—Clearance Hole in Door Stop required

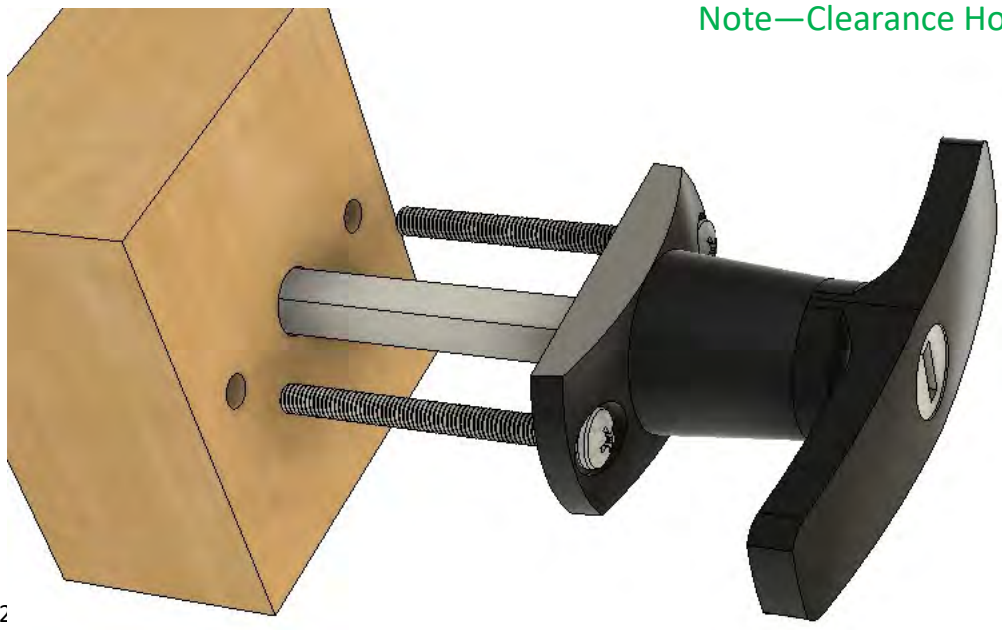

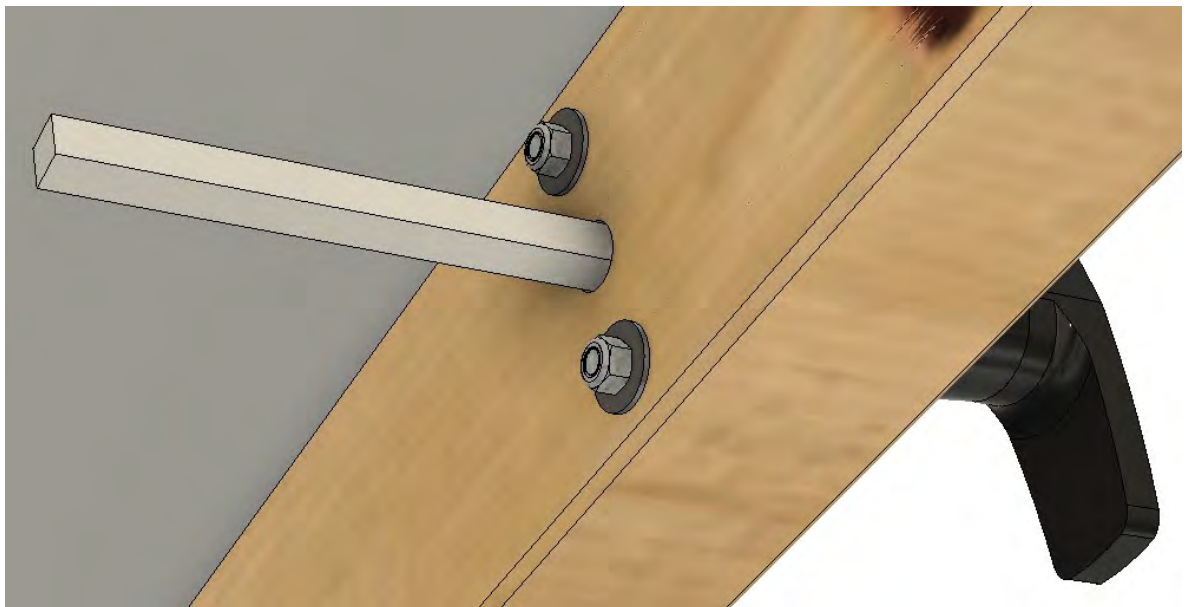
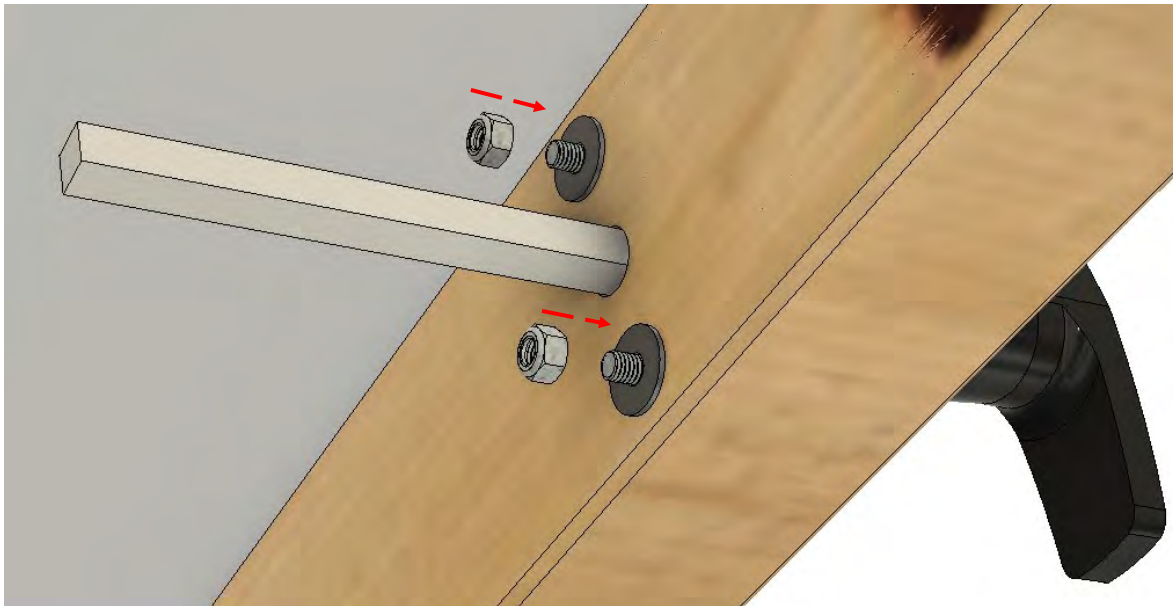
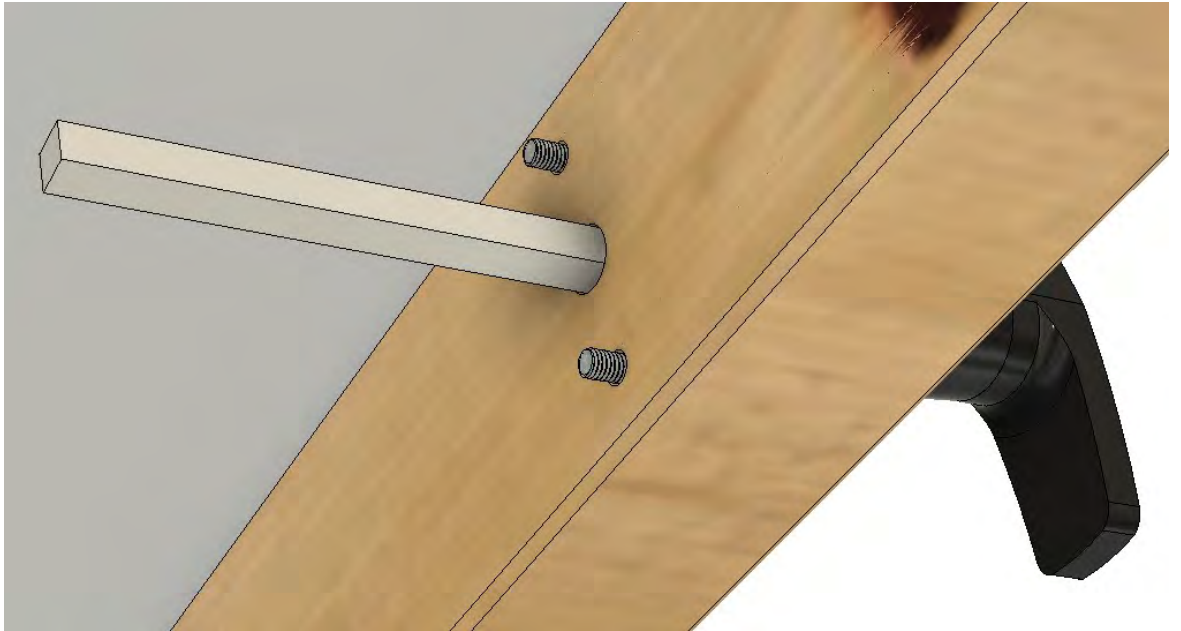

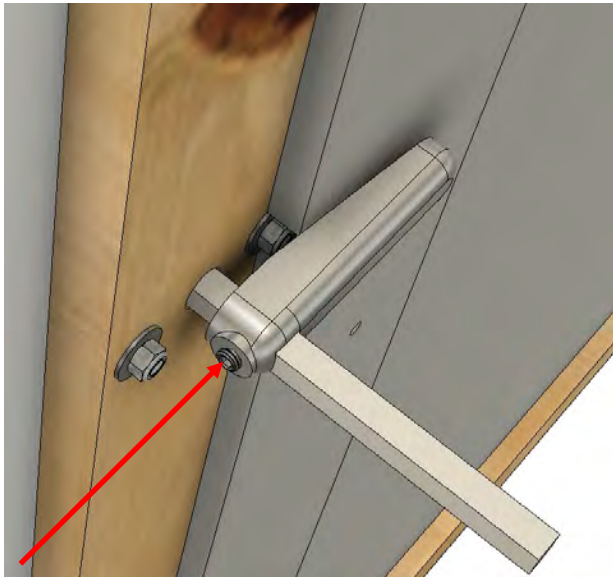
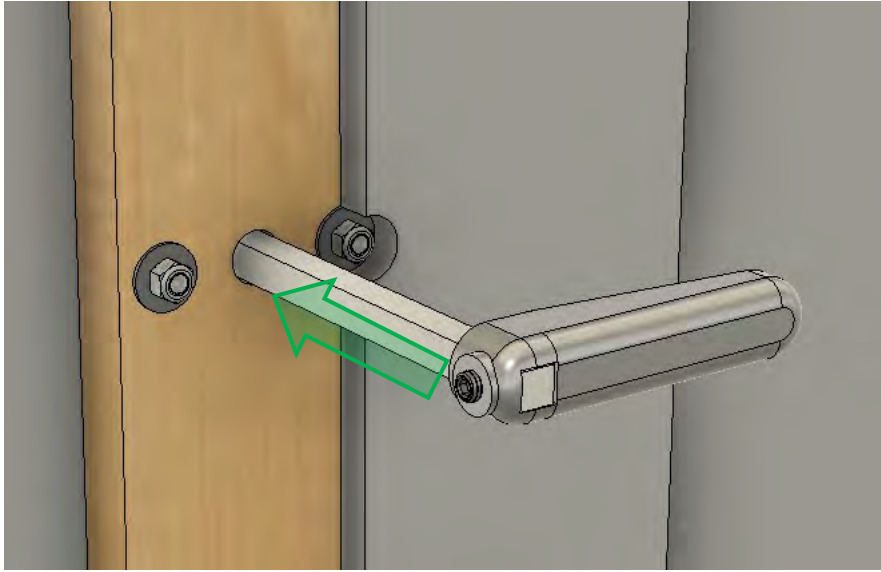

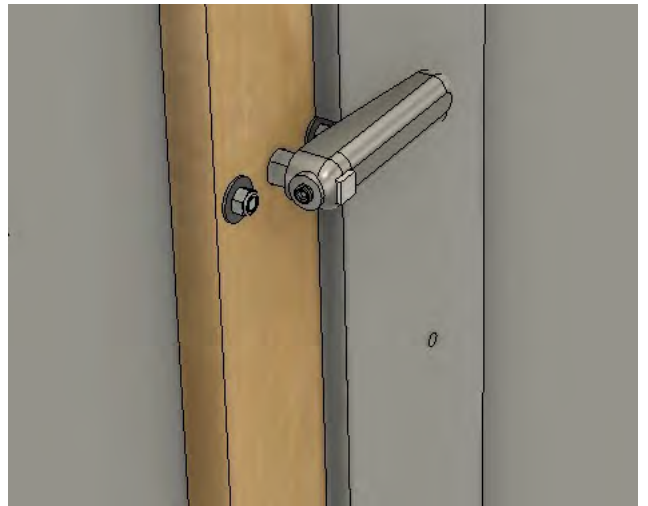

Optional: Trim excess length off Lock Square shaft.



Anchor Kit

<p>20</p>	<p>[11]</p>  <p>BKT6040G</p>	<p>[11]</p>  <p>SB650</p>	<p>[22]</p>  <p>RS25</p>
-----------	---	---	---

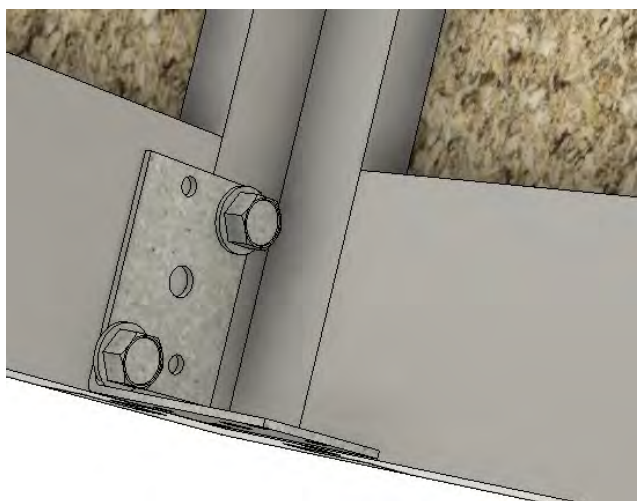
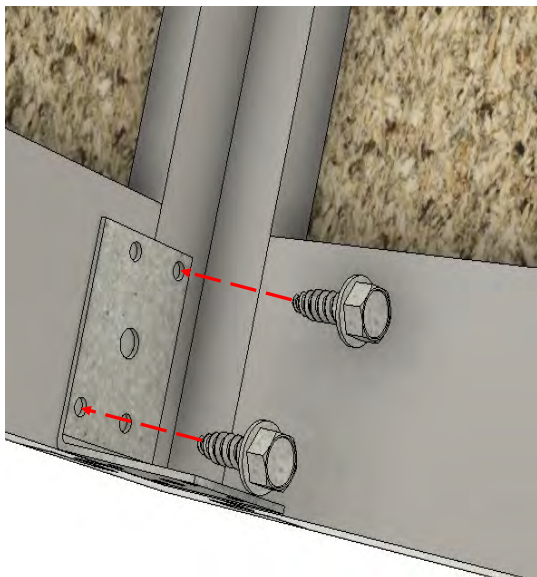
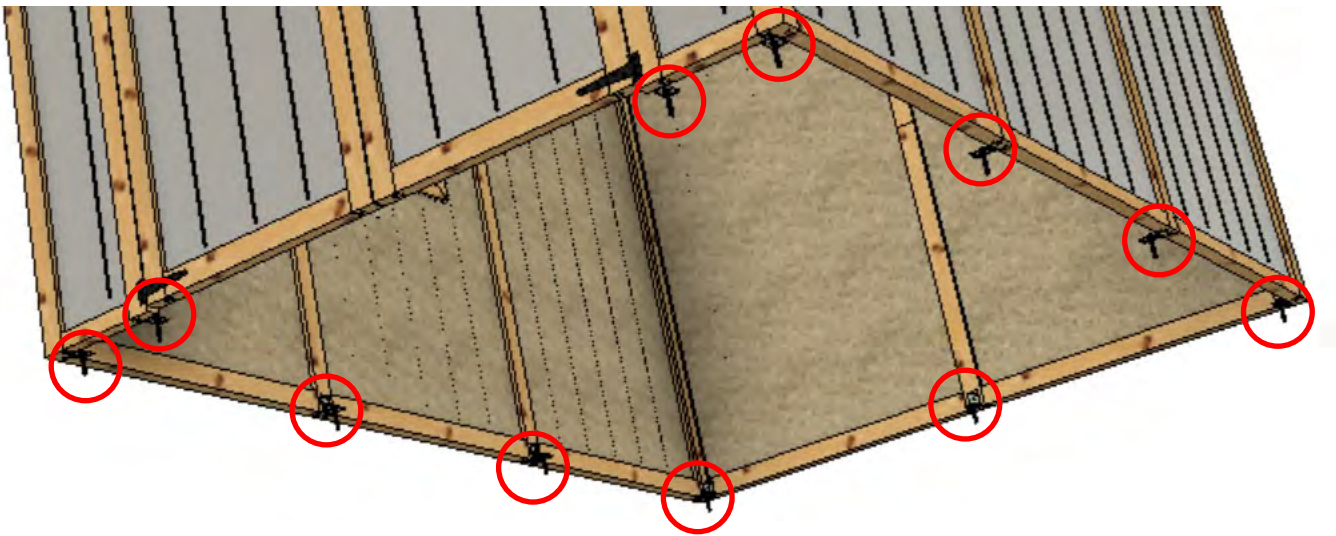

Bracket Positions

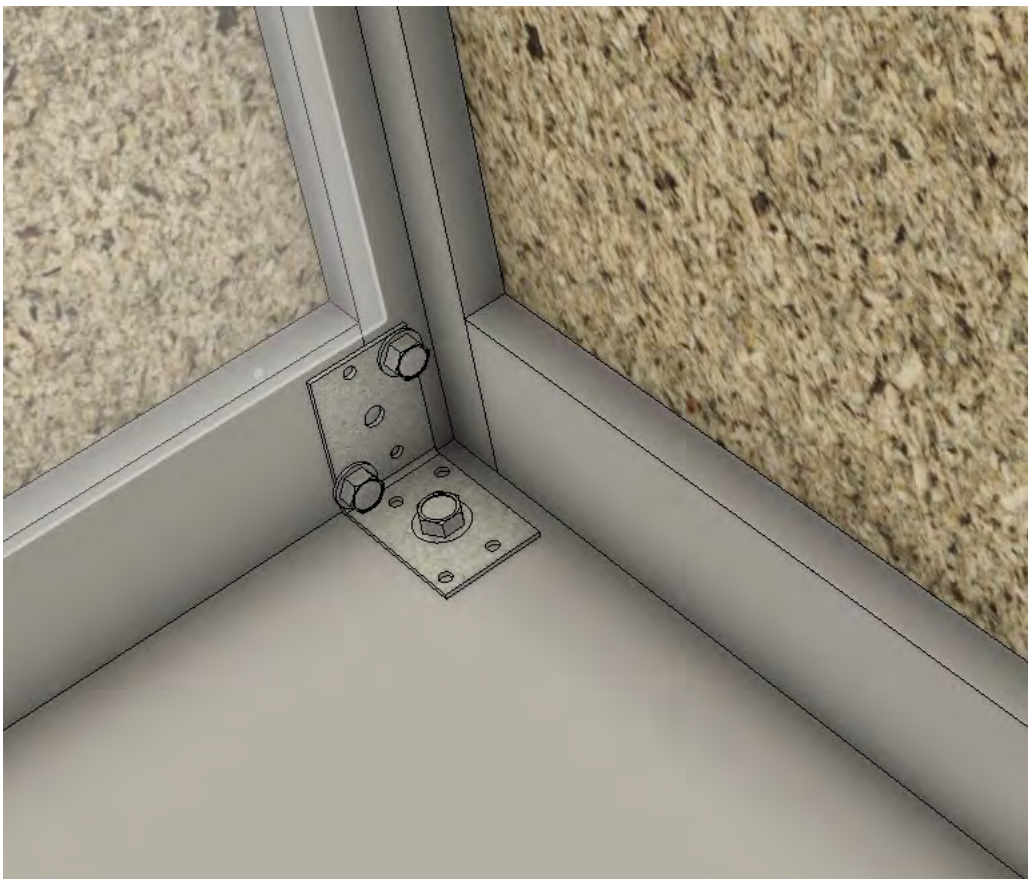
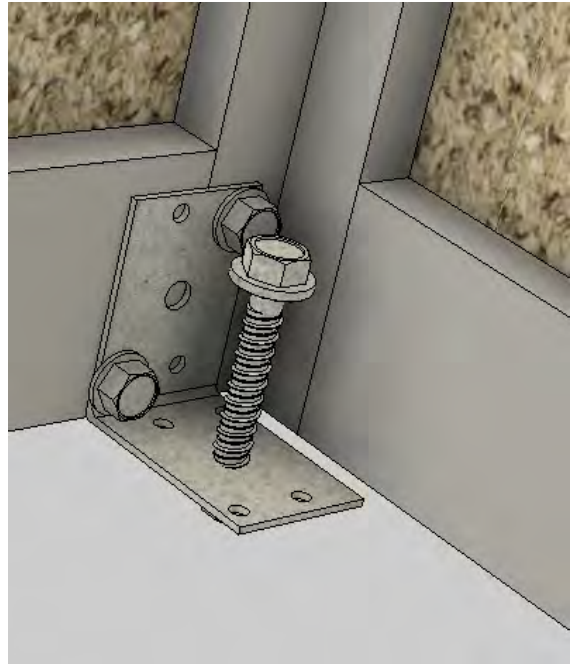

Masonry Drill 5mm, 50mm Deep



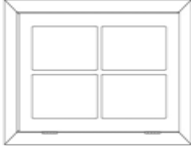

Insert Opening Window Frame

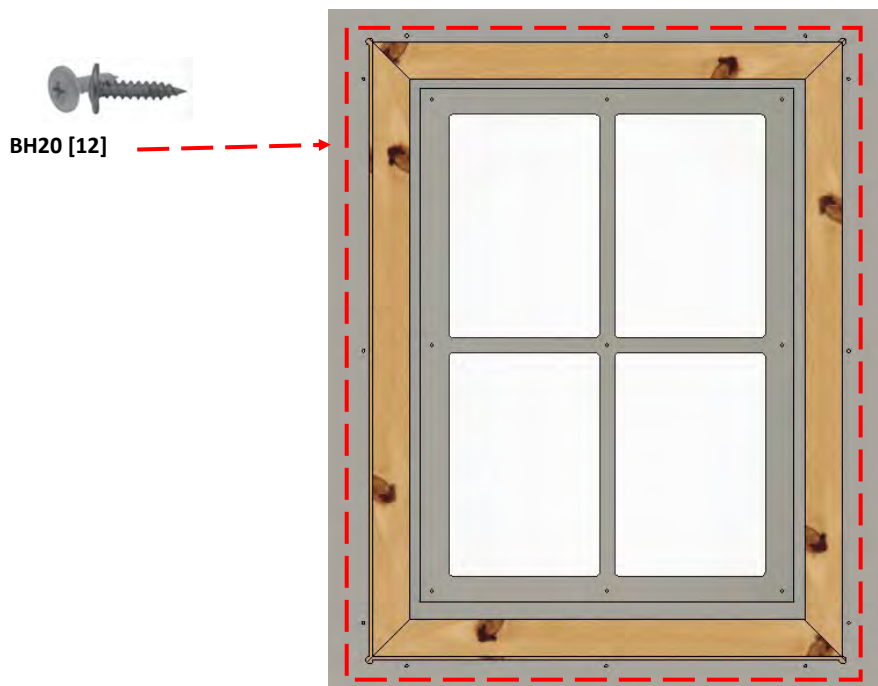
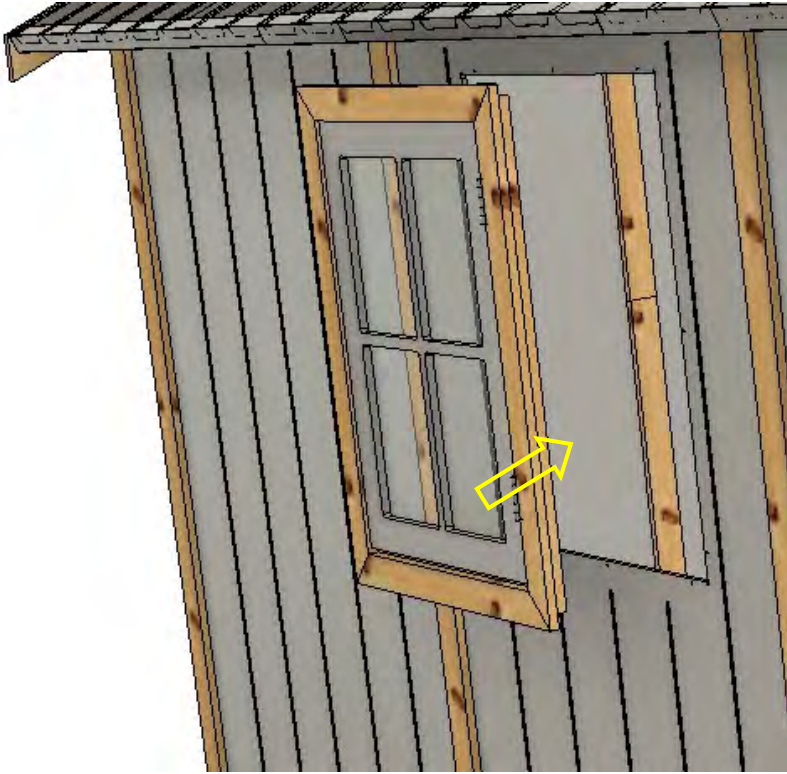
<p>(21)</p>	<p>[1]</p>  <p>Opening Window Assembly</p>	<p>[12]</p>  <p>FB20 MO/SM</p>
-------------	---	---



Finishing Touches

<div style="border: 1px solid black; border-radius: 50%; width: 40px; height: 40px; display: flex; align-items: center; justify-content: center; margin: 0 auto;">22</div>	<p>[1]</p>  <p>TU MO/SM, Paint Touchup Monument / Surfmist 500ml</p>	<p>[1]</p>  <p>Sil-MO/SM, Silicone sealant 300ml – coloured</p>
--	--	---

Once fully assembled. Check for any blemishes to the paintwork. Touch-up paint provided in assembly kit. Once paint is dry, seal bottom and sides of panels with supplied Silicone sealant.

TO REGISTER YOUR WARRANTY

Thank-you for purchasing a STILLA product. To register your 10 year product warranty, please go to www.stilla.com.au/warranty and complete the online form. We recommend that you complete this step once you have finished installing your product.

PLEASE NOTE THAT IF YOU DO NOT COMPLETE THIS WARRANTY REGISTRATION FORM – YOUR PRODUCT IS NOT COVERED BY WARRANTY.

PRODUCT MAINTENANCE

Paints and Sealant are Included in your installation kit. These can be purchased from Dulux paint stores or the paint section at Bunnings.